

# aumüller

## Assembly and Commissioning Instructions

according to Machinery Directive 2006/42/EC (annex VI)

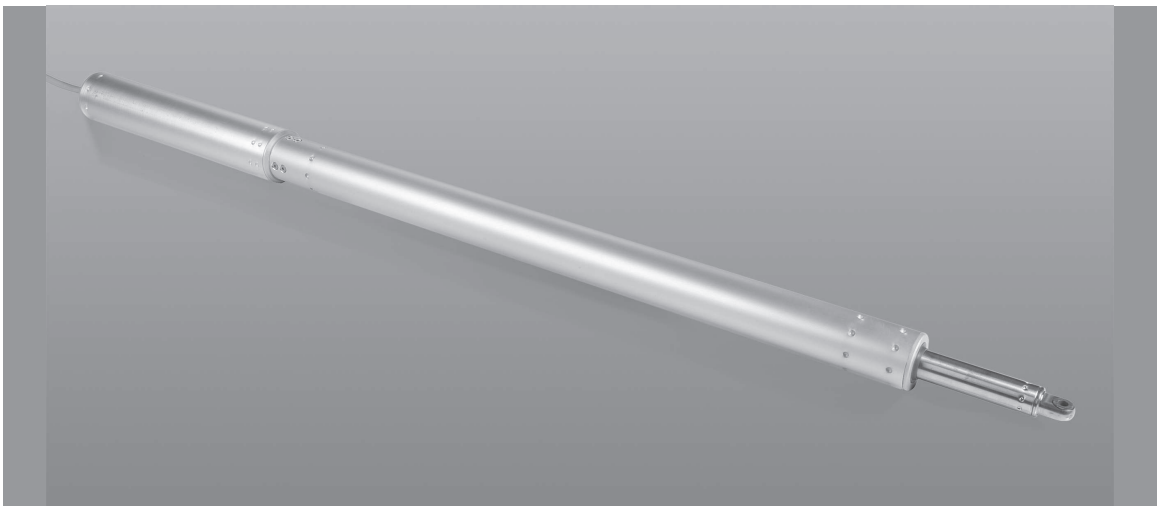

PLS S12 24V DC SPINDLE DRIVE FOR WINDOWS **CE**



01	<p>Abbreviations            Target Groups            Warning and Safety Symbols            Intended Use            Safety Instructions</p>	3 - 8
02	<p>Data sheet PLS15 S12 24V DC            Data sheet PLS30 S12 24V DC            Data sheet PLS50 S12 24V DC            Explanations on the product label</p>	9 - 14
03	<p>Areas of Application and Casement Sizes            Opening angle at direct operation</p>	15 - 16
04	<p><b>INSTALLATION STEP 1:</b> Inspection before the installation  <b>INSTALLATION STEP 2:</b> Installation prerequisite and Installation preparation</p>	17 - 18
05	<p><b>INSTALLATION STEP 3A:</b> Determine the casement brackets  <b>INSTALLATION STEP 3B:</b> Determine the frame brackets  <b>INSTALLATION STEP 4A/B:</b> Hole layout for frame bracket and casement bracket (Activation on HSK /NSK)  <b>INSTALLATION STEP 4C:</b> Sky light (Activation on HSK)</p>	19 - 24
06	<p><b>INSTALLATION STEP 5A:</b> Assembly for direct operation (Activation on HSK)  <b>INSTALLATION STEP 5B:</b> Assembly for side-closing edge operation (Activation on NSK)</p>	25 - 29
07	<p><b>INSTALLATION STEP 6:</b> Electric Connection  <b>INSTALLATION STEP 7:</b> Supply lines of drives to the control unit  <b>INSTALLATION STEP 8:</b> Safety check and Test run            Troubleshooting, Service and Repair            Maintenance and Modification</p>	30 - 33
08	<p>Removal and Disposal            Liability            Warranty and After-Sales Service            Certificates</p>	34 - 39

## ABBREVIATIONS

### Index of abbreviations

These abbreviations are used consistently throughout these assembly & operating instructions. Unless stated differently, all dimensions indicated in this document are in mm. General tolerances in accordance with DIN ISO 2768-m.

A	drive
AK	connection cable / drive cable
AP	cover cap
BD	hinge
Fxxx	casement bracket
FAB	overall width of casement
FAH	overall height of casement
FG	casement weight
FL	casement
FÜ	casement overlap
HSK	main closing edge
Kxxx	frame bracket
L	construction length of drive
MB	central hinge
NSK	side closing edge
RA	frame
RAB	overall width of frame
RAH	overall height of frame
SL	snow load
→	opening direction

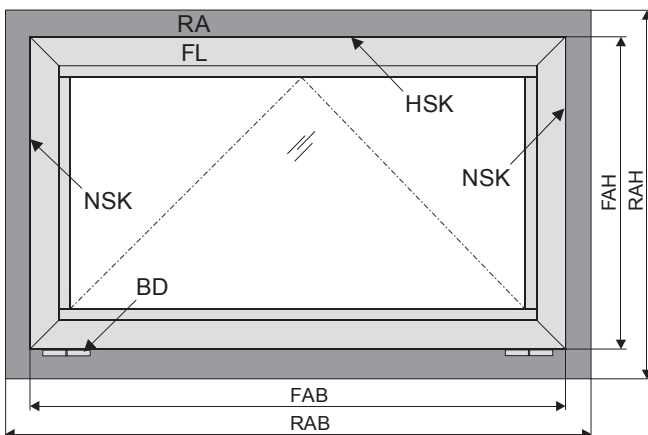

## TARGET GROUP

These instructions are intended for trained personnel and operators of systems for natural smoke ventilation (NRA / SHEV) (natural smoke exhaust system / smoke and heat exhaust system) and natural ventilation via windows, who are knowledgeable of operating modes as well as the remaining risks of the system.

## WARNING AND SAFETY SYMBOLS IN THESE INSTRUCTIONS:

The symbols used in the instructions shall be strictly observed and have the following meaning:



**DANGER**

Failure to comply with the warning notes results in irreversible injuries or death.



**WARNING**

Failure to comply with the warning notes can result in irreversible injuries or death.



**CAUTION**

Failure to comply with the warning notes can result in minor or moderate (reversible) injuries.



**NOTE**

Failure to comply with the warning notes can lead to damage to property.



**Caution / Warning**

Danger due to electric current.



**Caution / Warning**

Risk of crushing and entrapment during device operation (is provided as a sticker with the drive).



**Attention / Warning**

Risk of damage to / destruction of drives and / or windows.



**WARNING**

This device is not intended for use by persons (including children) with physical, sensory or mental limitations or lacking experience and / or knowledge, unless they are supervised by a person who is responsible for the safety or were instructed by him on the usage of this equipment. Children should be supervised to ensure that they are not playing with this device. Cleaning and operator's maintenance may not be performed by children without supervision.

## INTENDED USE

### Area of application / Scope of application

This drive is intended for the electromotive opening and closing of windows in facade and roof areas.

**The prime task of this product**, in combination with a window and a suitable external control unit, **is to evacuate hot smoke and combustion gases in case of fire**, to save human lives and protect material assets. Furthermore, combined with a suitable external control unit, the electromotive operated window ensures **fresh air supply for the natural ventilation** of the building.

#### NOTE

By attaching the drive to a movable element of the window a so-called "power-operated window" is created which, according to the Machinery Directive 2006 / 42 / EG, represents a machine.

### Intended use according to the Declaration of Conformity

The drive is intended for stationary installation and electrical connection at the window as part of a building.

In accordance with the attached Declaration of Conformity the drive, in combination with an external Control Unit from AUMÜLLER, is released for its intended use at a power-operated window **without an additional on-site risk assessment** for the following use:

- Application for natural ventilation
  - with an installation height of the drive of at least 2,5 m above the floor, or
  - with an opening width at the HSK of the operated element of < 200 mm by a simultaneous speed of < 15 mm/s at the HSK in closing direction.
- Application as NSHEV (natural smoke and heat exhaust ventilators) for ventilation without dual function for ventilation in accordance with EN12101-2.

Attention must be paid to possible hazards when used with tilting or rotating windows, whose secondary closing edges are located at less than 2,5 m installation height above the floor, under consideration of the Control Unit and usage!

#### ⚠ WARNING

We as manufacturers are well aware of our duties and responsibilities regarding the development, manufacturing and placing of safe window drives on the market and consistently implement them. Ultimately, however, we have no direct influence on the usage of our drives. Therefore, as a precaution, we point out the following:

- The **constructor or his agent** (architect, specialist planner) **are obligated** by law **to evaluate the hazards to persons**, originating from the usage, installation position, opening parameters as well as the planned type of installation of the power operated window and the external Control Unit, **already in the planning phase and to establish necessary protective measures.**
- The **constructor / manufacturer** of the machine "power-operated window" **must implement** the planned **protective measures** at the installation site or, if not yet established, **determine them** by their own responsibility and detect or **minimize possible remaining risks.**

**The need for a risk assessment at the installation site due to the reasonably foreseeable misuse.**

**A risk assessment in accordance with the Machinery Directive 2006 / 42 / EG for the usage of the power-operated window for natural ventilation is absolutely necessary** under the following conditions:

- the installation height of the drive is < 2,5 m above the floor **and**
- the opening width at the HSK > 200 mm, **or**
- the closing speed at the HSK is > 15 mm/s, **or**
- the opening speed at the HSK is > 50 mm/s, **or**
- the closing force at the HSK is > 150 N

The following flow chart can be applied, which also includes the protective measures in accordance with EN 60335-2-103/2016-05.

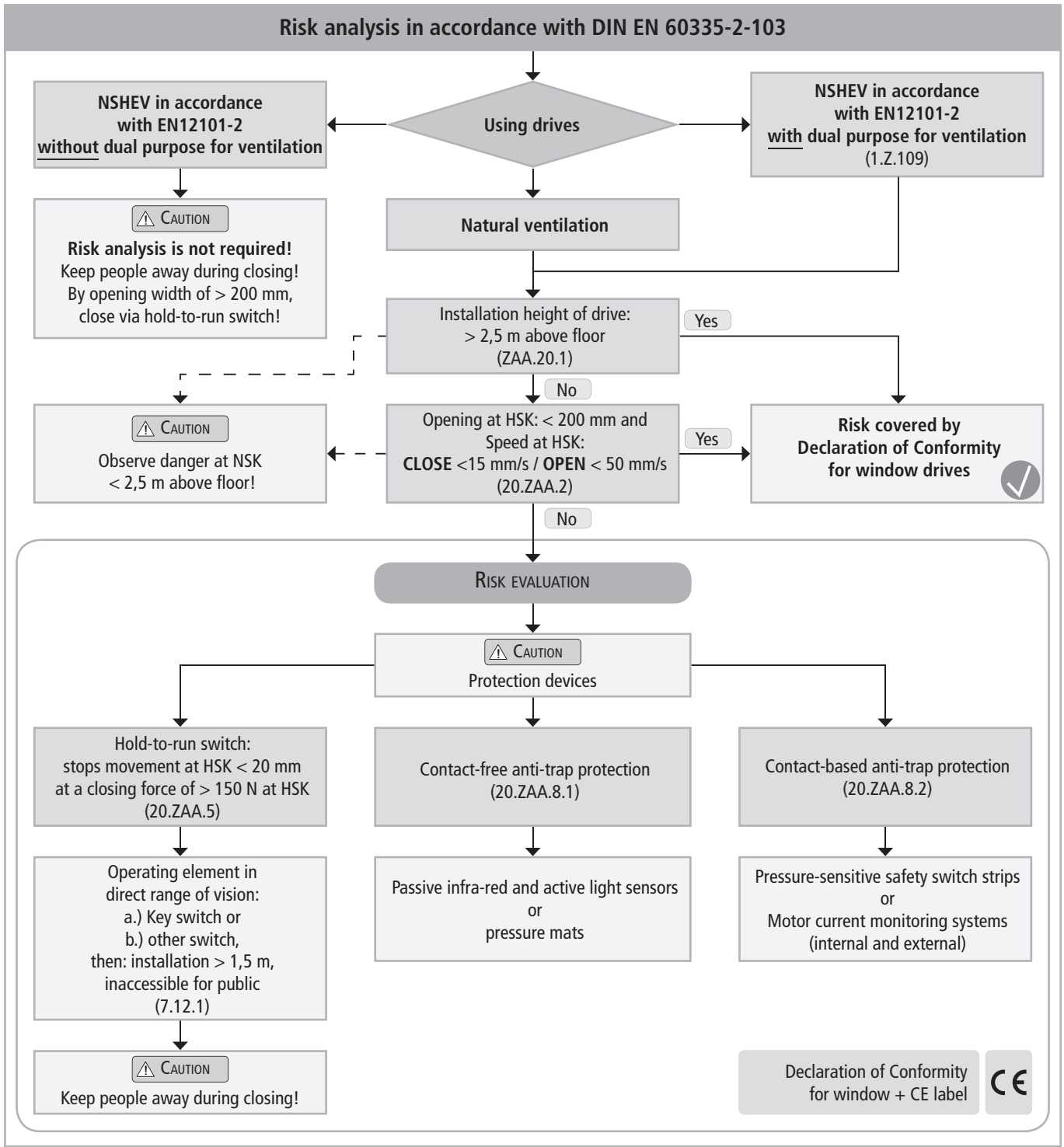

**Casement data**

Facade: bottom-hung window, top-hung window, side-hung window.  
 Dach: roof window / sky light.  
 Opening direction: inward / outward opening.  
 Profile material: aluminum, steel, plastic or wood.

**NOTE**

The casement measurements supplied are only for orientation purposes. It is imperative that the **force-path diagram** of the drives are observed.

When inspecting the drives for conformity with on-site requirements the following items must be observed:

- total weight of casement (glass + frame),
- additional loads: snow load / wind load (suction / pressure),
- casement size (FAB x FAH),
- side ratio FAB / FAH,
- installation / inclination angle,
- required opening area (geometric / aerodynamic),
- crosswind influences,
- driving force and stroke,
- mounting site at the window frame and casement frame.

**SAFETY INSTRUCTIONS**



It is important to follow these instructions for the safety of persons. These instructions shall be kept in a safe place for the entire service life of the products.

**Risk of crushing and entrapment!  
Window can close automatically!**

The integrated load cut-off stops the drive during closing and opening when the drive is overloaded.

**The compressive force is absolutely sufficient to crush fingers in case of carelessness.**



**Area of application**

The drive shall only be used according to its intended use. For additional applications consult the manufacturer or his authorized dealer.

Do not misuse the drive for other lifting operations! Do not allow children to play with this drive or its regulating and / or control units, including the remote control!



Always check whether the system complies with current regulations. Special attention must be paid to the opening width, the opening area, the opening time and the opening speed of the window, the temperature range of the drives / external devices and cables as well as the cross section of the connecting cables as function of the cable length and power consumption.



All devices must be permanently protected from dirt and moisture, if the drive is not explicitly suitable for use in wet areas (see technical data).

**Installation**

These instructions address expert and safety-conscious electricians and / or qualified personnel knowledgeable in electrical and mechanical drive installation.

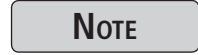

The safe operation, avoidance of injury to persons and damage to property, as well as risks, is only guaranteed by proper installation and setting according to these installation instructions.

All specifications for installation must be checked independently and, if necessary, adjusted at the installation site. The connection assignment, the electrical supply data (see machine plate) and performance limits (see technical data) as well as the mounting and installation instructions of the drive must be strictly observed and adhered to!



Never connect 24 V DC drives to 230 V AC mains voltage!  
**Danger to life!**

Do not reach into the window rabbet or the operating element (chain or spindle) during installation and operation! Ensure that, based on the installation position and the opening movement of the casement, persons cannot be trapped between the driven part of the window and surrounding fixed components (e.g. wall).

**Mounting material**

The required mounting material must be modified to fit the drive and occurring load and, if necessary, supplemented.



Before installing the drive, check whether the casement is in good mechanical condition, the weight in balance and whether it opens and closes easily!

**Danger spots by crush and shear points**

<p>Side-hung</p>	<p>Bottom-hung</p>	<p>Roof windows / skylight domes</p>	<p>Louvre windows</p>
<p> Danger spots: crush and shear points according to DIN EN 60335-2-103</p>			

### Crush and shear points

To avoid injuries, **crushing and shear points** between casement and frame must be secured **against entrapment up to an installation height of 2,5 meters above the floor** with appropriate measures. This can be achieved e.g. by using contact-based or contactless protective devices against entrapment, which stop the motion through contact or through interruption by a person. At a force higher than 150 N at the main closing edge the motion must stop within 20 mm. A warning symbol at the opening element must indicate this clearly.

### Unintentional or independent opening or falling

Casements are to be hinged or secured such way that in case one of the mounting elements fails it will not crash / slam down or move in an uncontrolled manner by e.g. using double suspensions, safety scissors, casement stays. Tilting windows shall be equipped with safety scissors or similar devices to avoid damages and risks of injury for persons through improper installation and operation. The safety scissors must be adjusted to the opening stroke of the drive (see technical data) to avoid blocking. The opening width of the safety scissors must be bigger than the drive stroke.



**WARNING**

The movable casement must be secured against unintentional or independent opening as well as falling down.

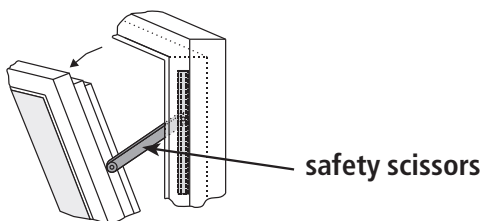

### Routing cables and electrical connection

Routing or installing electrical lines and connections may be performed only by approved specialist companies. Never operate drives, control units, operating elements and sensors at operating voltages and connections contrary to the specifications of the manufacturer.

All relevant instructions shall be observed for the installation, specifically:

- VDE 0100 Setting up high-voltage systems up to 1000 V
- VDE 0815 Wiring cables
- Specimen Guideline on Conduits German designation (MLAR).



All-pole disconnecting devices shall be installed in the permanent electrical installation or external Control Unit for the drive.

The mains supply lines 230 V / 400 V AC shall be protected separately!



**WARNING**

Damaged mains supply lines of drives with plug connectors may only be replaced by the manufacturer or qualified service / maintenance personnel!

Power cables which are fixed to the drive casing cannot be replaced. If the cable is damaged the device must be scrapped!

The types of cable, cable lengths and cross-sections shall be selected in accordance with the manufacturer's technical data. If necessary, the cable types shall be coordinated with the competent local authorities and energy supply companies. Low-voltage lines (24 V DC) shall be routed separate from the high-voltage lines. Flexible cables may not be flush-mounted. Freely suspended cables shall be equipped with strain reliefs.



Cables must be laid such way that they cannot be sheared off, twisted or bent during operation. Drive cables laid into closed window profiles must be protected by insulating tubes with a sufficient temperature resistance. Through holes shall be equipped with cable sleeves!

Clamping points shall be checked for tightness of threaded connections and cable ends. Access to junction boxes, clamping points and external drive control systems shall be ensured for maintenance work.

### Commissioning, operation and maintenance

After the installation and after each modification in the set up all functions shall be checked with a trial run. It shall be ensured that drive and casement are set correctly and that security systems, if available, are functioning properly. After the installation of the system is completed the end-user shall be introduced to all important operating steps. If necessary, he must be advised of all remaining risks / dangers.

The end-user shall be instructed in intended use of the drives and, if necessary, the safety instructions. The end-user shall be specifically instructed that no additional forces, except for the pressure and tension in the opening and closing direction of the casement, may be applied to the spindle, chain or lever of the drive.

**NOTE**

Post warning signs!

During the proper assembly of drives with mounting elements at a window, and the connection to an external control unit, the interfaces resulting from mechanical and electrical performance characteristics of single elements shall be observed.

 **CAUTION**

Other persons must be kept away from the casement when a hold-to-run switch (pushbutton) is operated or when a window, which has been opened by a smoke and heat exhaust system, is closing!

 **CAUTION**

The operating element of hold-to-run switches must be installed within direct view from the window, but apart from moving elements. If the switch is not a key-operated switch it must be installed at a minimum height of 1,5 m and inaccessible to the public!

 **CAUTION**

Do not allow children to play with permanently mounted control devices and keep remote controls out of reach for children!



During cleaning, maintenance work and while exchanging parts the drive must be completely disconnected from the power supply and secured against unintentional reactivation.

 **WARNING**

Do not use drive or casement when repair or re-setting work has to be performed!

**Replacement parts, fasteners and controls**

The drive shall only be operated with control devices from the same manufacturer. There is no liability, warranty or customer service if third-party parts are used. Exclusively original replacement parts of the manufacturer shall be used for mounting elements or expansions.

**Ambient conditions**

The product may not be subjected to impacts or falls, or to vibrations, moisture, aggressive vapors or other harmful environments, unless the manufacturer released it for one or more of these environmental conditions.

• **Operation:**

- Ambient temperature: -5 °C ... +75°C
- Relative humidity: < 90% less 20°C;  
< 50% less 40°C;  
no formation of condensation

• **Transport / Storage:**

- Storage temperature: -5°C ... +40°C
- Relative humidity: < 60%

**Accident prevention regulations and workmen's compensation insurance guidelines**

For work on or in a building or building part the provisions and instructions of the respective accident prevention regulations (UVV and workmen's compensation insurance guidelines (BGR /ASR) shall be observed and adhered to.

**Declaration of Conformity**

The drive is manufactured and inspected in accordance with European guidelines. The respective Declaration of Conformity is on hand.

**In case the operation of the drive differs from the intended use, a risk evaluation for the complete power-operated window system shall be performed and a Declaration of Conformity according Machinery Directive 2006 / 42 / EG issued.**



DATA SHEET PLS15 S12 24V DC

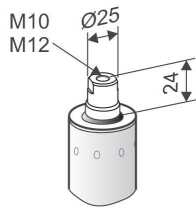

OPTION

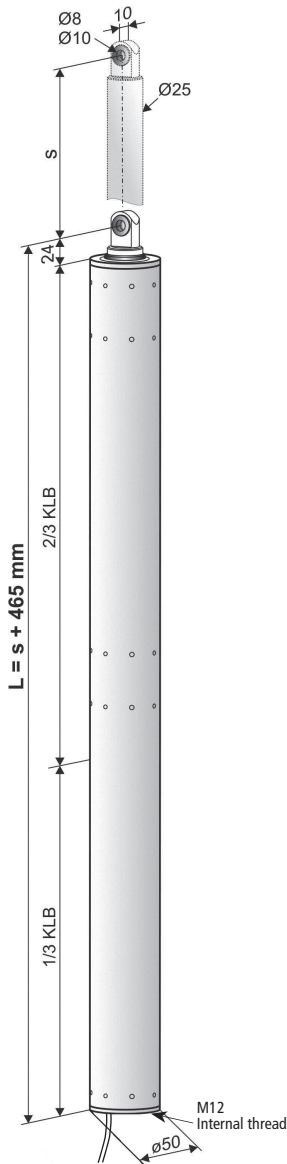

OPTION

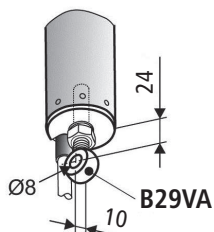

- Application: natural ventilation, SHEV, ferralux®-NSHEV

Options

- Spindle tube with interior thread for clevis
- Spindle tube with interior thread for clevis

S12

- Internal intelligent cut-off switch S12

Options

- Programmable synchronised run (max. 4 drives) and special functions
- M-COM for automatic synchronised run of multi drive systems and automatic sequence control with FV locking drives (S3/S12 SW V2)

TECHNICAL DATA

$U_N$	Rated voltage	24V DC ( $\pm 20\%$ ), max. 2 Vpp
$I_N$	Rated current	3,0 A
$I_A$	Cut-off current	4,0 A
$P_N$	Rated power	72 W
ED	Duty cycle	30 % (ON: 3 min./OFF: 7 min.)
	Protection rating	IP 54
	Ambient temperature range	-5 °C ... +75 °C
$F_z$	Pulling force max.	1500 N
$F_A$	Pushing force	

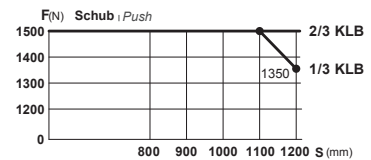

$F_H$	Pullout force	25000 N (fastening depended))
	Spindle tube	Stainless steel
	Connecting cable	Non-halogen, grey 3 x 1,0 mm <sup>2</sup> , ~ 3 m
v	Speed	$\times$ 16,0 mm/s $\curvearrowright$ 16,0 mm/s
s	Stroke	300 – 1000 mm ( $\pm 5\%$ )
L	Length	s + 465 mm (see order data)
	Sound pressure level A	$\leq 70$ dB (A)

**ORDER DATA**

s [mm]	L [mm]	Version	Finish	PU / pcs.	Part.-No.
300	765	PLS15 300 S12	E6/C-0	1	<b>576830</b>
400	865	PLS15 400 S12	E6/C-0	1	<b>576840</b>
500	965	PLS15 500 S12	E6/C-0	1	<b>576850</b>
600	1065	PLS15 600 S12	E6/C-0	1	<b>576860</b>
750	1215	PLS15 750 S12	E6/C-0	1	<b>576875</b>
1000	1465	PLS15 1000 S12	E6/C-0	1	<b>576800</b>
1200	1665	PLS15 1200 S12	E6/C-0	1	<b>576812</b>

**OPTIONS**

Special model	PU / pcs.	Part.-No.
<b>Front / Rear Fixing</b>		
Spindle tube end with interior thread M10	1	<b>515062</b>
Spindle tube end with interior thread M12	1	<b>515063</b>
<b>Drive housing painted/powder coated in other RAL colours</b>		
Specify at order stage:	1 – 4	<b>516004</b>
	5 – 9	<b>516004</b>
	10 – 49	<b>516004</b>
	50 – 99	<b>516004</b>
	ab 100	<b>516004</b>
<b>Extra length connecting cable:</b>		
5 m – non-halogen, grey – 3 x 1,0 mm <sup>2</sup>		<b>501037</b>
10 m – non-halogen, grey – 3 x 1,0 mm <sup>2</sup>		<b>501039</b>
<b>Accessories for front / rear suspension</b>		
B29VA Eyebolt M12x40mm, Ø8 mm, Stainless steel	1	<b>105430</b>
B28ST Clevis M10x20 mm, galvanized, thread M10x50 mm	1	<b>105520</b>
<b>Microprocessor programming S12</b>		
Electronic stroke reduction without lengths reduction for S12	1	<b>524190</b>
Electronic stroke reduction with lengths reduction for S12	1	<b>515990</b>
Special functions	1	<b>524180</b>
<b>Optional accessories</b>		<b>Part.-No.</b>
M-COM Comm. module for synchronised multi-drive systems	1	<b>524177</b>

DATA SHEET PLS30 S12 24V DC

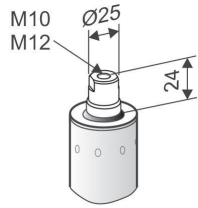

OPTION

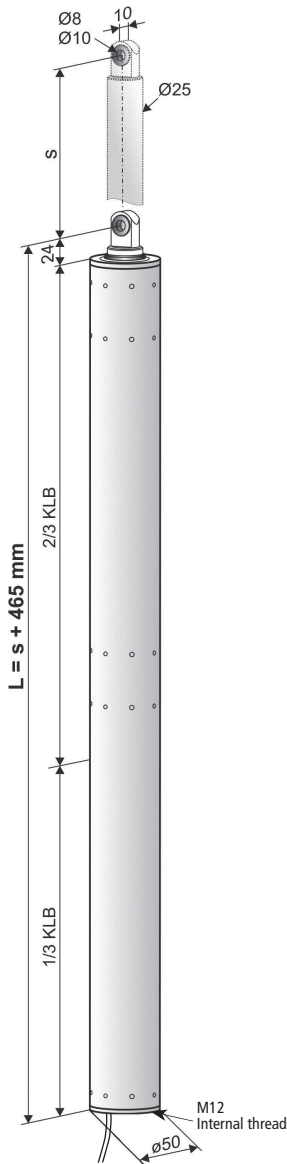

OPTION

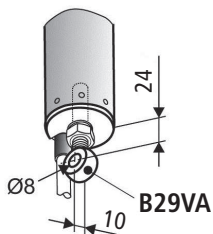

- Application: natural ventilation, SHEV, ferralux®-NSHEV
- Options**
- Spindle tube with interior thread for clevis
- Eyebolt and clevis for rear suspension

**S12**

- Internal intelligent cut-off switch S12
- Options**
- Programmable synchronised run (max. 4 drives) and special functions
- M-COM for automatic synchronised run of multi drive systems and automatic sequence control with FV locking drives (S3/S12 SW V2)

**TECHNICAL DATA**

$U_N$	Rated voltage	24V DC ( $\pm 20\%$ ), max. 2 Vpp
$I_N$	Rated current	3,8 A
$I_A$	Cut-off current	5,0 A
$P_N$	Rated power	91 W
ED	Duty cycle	30 % (ON: 3 min./OFF: 7 min.)
	Protection rating	IP 54
	Ambient temperature range	-5 °C ... +75 °C
$F_Z$	Pulling force max.	3000 N
$F_A$	Pushing force max.	

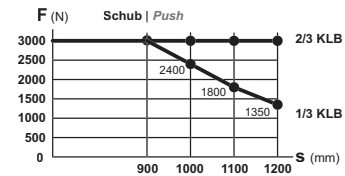

$F_H$	Pullout force	25000 N (fastening depended))
	Spindle tube	Stainless steel
	Connecting cable	Non-halogen, grey 3 x 1,0 mm <sup>2</sup> , ~ 3 m
v	Speed	$v_{\text{rot}}$ = 7,8 mm/s $v_{\text{trans}}$ = 7,8 mm/s
s	Stroke	300 – 1000 mm ( $\pm 5\%$ )
L	Length	s + 465 mm (see order data)
	Sound pressure level A	$\leq 70$ dB (A)

**ORDER DATA**

s [mm]	L [mm]	Version	Finish	PU / pcs.	Part.-No.
300	765	PLS30 300 S12	E6/C-0	1	577530
400	865	PLS30 400 S12	E6/C-0	1	577540
500	965	PLS30 500 S12	E6/C-0	1	577550
600	1065	PLS30 600 S12	E6/C-0	1	577560
750	1215	PLS30 750 S12	E6/C-0	1	577575
1000	1465	PLS30 1000 S12	E6/C-0	1	577500
1200	1665	PLS30 1200 S12	E6/C-0	1	577512

**OPTIONS**

Special model	PU / pcs.	Part.-No.
<b>Front / Rear Fixing</b>		
Spindle tube end with interior thread M10	1	515062
Spindle tube end with interior thread M12	1	515063
<b>Drive housing painted/powder coated in other RAL colours</b>		
Specify at order stage:	1 – 4	516004
	5 – 9	516004
	10 – 49	516004
	50 – 99	516004
	ab 100	516004
<b>Extra length connecting cable:</b>		
5 m – non-halogen, grey – 3 x 1,0 mm <sup>2</sup>		501037
10 m – non-halogen, grey – 3 x 1,0 mm <sup>2</sup>		501039
<b>Accessories for front / rear suspension</b>		
B29VA Eyebolt M12x40mm, Ø8 mm, Stainless steel	1	105430
B28ST Clevis M10x20 mm, galvanized, thread M10x50 mm	1	105520
<b>Microprocessor programming S12</b>		
Electronic stroke reduction without lengths reduction for S12	1	524190
Electronic stroke reduction with lengths reduction for S12	1	515990
Special functions	1	524180
<b>Optional accessories</b>		PU / pcs. Part.-No.
M-COM Comm. module for synchronised multi-drive systems	1	524177

# DATA SHEET PLS50 S12 24V DC

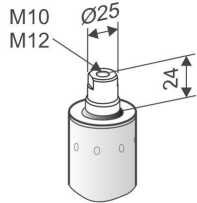

OPTION

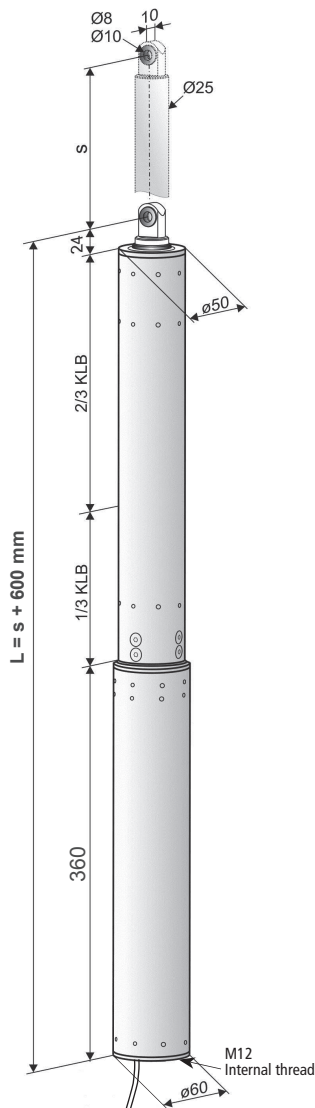

OPTION

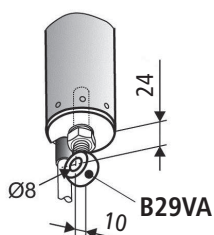

- Application: natural ventilation, SHEV
- Options**
- Spindle tube with interior thread for clevis
- Eyebolt and clevis for rear suspension

**S12**

- Internal intelligent cut-off switch S12
- Options**
- Programmable synchronised run (max. 4 drives) and special functions
- M-COM for automatic synchronised run of multi drive systems and automatic sequence control with FV locking drives (S3/S12 SW V2)

**TECHNICAL DATA**

$U_N$	Rated voltage	24V DC ( $\pm 20\%$ ), max. 2 Vpp
$I_N$	Rated current	3,0 A
$I_A$	Cut-off current	4,2 A
$P_N$	Rated power	72 W
ED	Duty cycle	30 % (ON: 3 min./OFF: 7 min.)
	Protection rating	IP 54
	Ambient temperature range	-5 °C ... +75 °C
$F_Z$	Pulling force max.	5000 N
$F_A$	Pushing force	
$F_H$	Pullout force	25000 N (fastening depended))
	Spindle tube	Stainless steel
	Connecting cable	Non-halogen, grey 3 x 1,0 mm <sup>2</sup> , ~ 3 m
$v$	Speed	$v_{\text{push}} = 4,0 \text{ mm/s}$ $v_{\text{pull}} = 4,0 \text{ mm/s}$
$s$	Stroke	200 – 750 mm ( $\pm 5\%$ )
$L$	Length	$s + 600 \text{ mm}$ (see order data)
	Sound pressure level A	$\leq 70 \text{ dB (A)}$

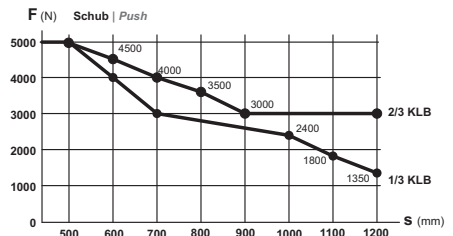

**ORDER DATA**

s [mm]	L [mm]	Version	Finish	PU / pcs.	Part.-No.
200	800	PLS50 200 S12	E6/C-0	1	577620
300	900	PLS50 300 S12	E6/C-0	1	577630
400	1000	PLS50 400 S12	E6/C-0	1	577640
500	1100	PLS50 500 S12	E6/C-0	1	577650
600	1200	PLS50 600 S12	E6/C-0	1	577660
750	1350	PLS50 750 S12	E6/C-0	1	577675

**OPTIONS**

Special model	PU / pcs.	Part.-No.
<b>Front / Rear Fixing</b>		
Spindle tube end with interior thread M10	1	515062
Spindle tube end with interior thread M12	1	515063
<b>Drive housing painted/powder coated in other RAL colours</b>		
Specify at order stage:	1 – 4	516004
	5 – 9	516004
	10 – 49	516004
	50 – 99	516004
	ab 100	516004
<b>Extra length connecting cable:</b>		
5 m – non-halogen, grey – 3 x 1,0 mm <sup>2</sup>		501037
10 m – non-halogen, grey – 3 x 1,0 mm <sup>2</sup>		501039
<b>Accessories for front / rear suspension</b>		
B29VA Eyebolt M12x40mm, Ø8 mm, Stainless steel	1	105430
B28ST Clevis M10x20 mm, galvanized, thread M10x50 mm	1	105520
<b>Microprocessor programming S12</b>		
Electronic stroke reduction without lengths reduction for S12	1	524190
Electronic stroke reduction with lengths reduction for S12	1	515990
Special functions	1	524180
<b>Optional accessories</b>		
M-COM Comm. module for synchronised multi-drive systems	1	524177

**EXPLANATIONS ON THE PRODUCT LABEL**

The product label provides information about:

- manufacturer,
- article reference number and name,
- technical characteristics,
- date of manufacturing with firmware version,
- serial number.

**NOTE**

Never install and operate damaged products.

In the event of any complaints, please indicate the product serial number (SN) (see product label).

The diagram shows a product label with the following information:

- Manufacturer:** aumüller, D-86672 Thierhaupten, Gemeindefeld 11, Tel. +49 8271 / 8185-0
- Model:** PLS 50 400 S12 24V
- Technical Data:**
  - s: 400 mm
  - U<sub>N</sub>: 24V  $\overline{\text{---}}$  2 V<sub>pp</sub>
  - I<sub>A</sub>: 4,2 A
  - F<sub>z</sub>: 5000 N
  - IP: 54
  - ED: 3 min / 7 min (on/off)
- Identification:**
  - Barcode
  - Serial number: 33942410002
  - Article number: 577640
- Compliance & Origin:**
  - CE mark
  - Temperature range: -5°C to +75°C
  - Made in Germany
- Operational Info:**
  - overload disconnection stroke
  - Duty cycle: ON: 3 minutes, OFF: 7 minutes
- Other Labels:**
  - overload disconnection stroke
  - date of manufacturing with firmware version

**AREAS OF APPLICATION AND CASEMENT SIZES**

**Areas of application and casement sizes:**

Mounting of drives up to a casement size of max. 4m<sup>2</sup> (depending on the system)

**Top-hung casement and Bottom-hung casement outward opening** **NSK**

FAB max. = 1200 mm / solo = 2500 mm / tandem	FAH max. = 2500 mm
---	--------------------

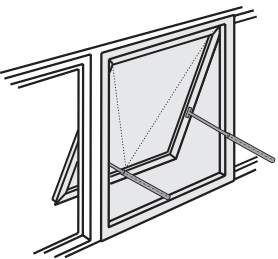

Top-hung casement

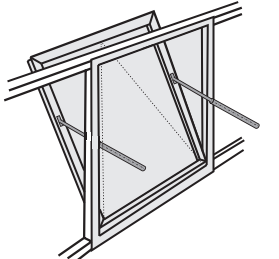

Bottom-hung casement

---

**Top-hung casement und Bottom-hung casement outward opening** **HSK**

FAB max. = 1200 mm / solo = 2500 mm / tandem	FAH max. = 2500 mm
---	--------------------

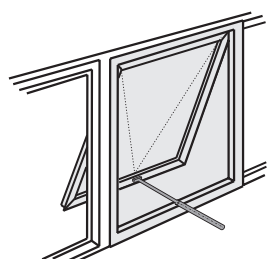

Top-hung casement

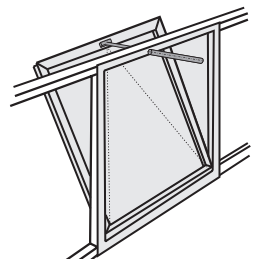

Bottom-hung casement

**Roof window** **HSK**

FAB max. = 1200 mm / solo = 2500 mm / tandem	FAH max. = 2500 mm
---	--------------------

total weight casement including snow load

PLS15 max. 270 kg  
PLS30 max. 550 kg  
PLS50 max. 900 kg

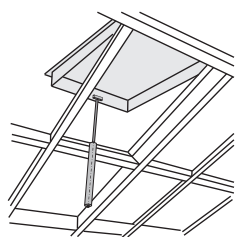

Top-hung casement

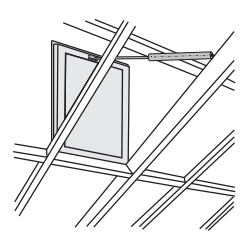

Bottom-hung casement

**Snow load on roof windows for SHEV-systems**

Example:  
snow load = 60 kg  
(Casement area x Typical snow load)

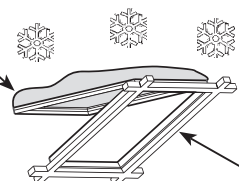

Example: FG = 40 kg

**Example calculation**  
Establish snow loading based on national standards /directives  
(in Germany according to DIN 1055-5)  
total weight = FG + snow load  
total weight = (40 kg + 60 kg) = 100 kg

OPENING ANGLE AT DIRECT OPERATION (OUTWARD OPENING WINDOWS)

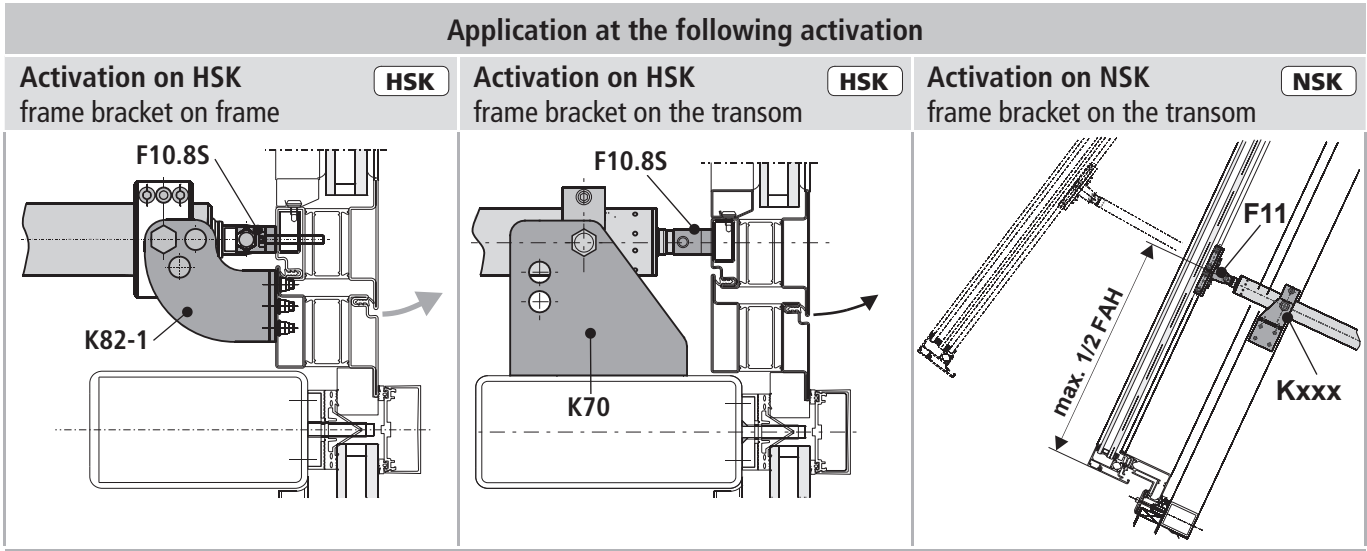

03

**Planning the opening angle for direct operation**

This planning diagram is a general guide to help establish the most appropriate drive stroke for the opening width required. The specific installation conditions are to be observed. The opening angle for direct operating drives on the main closing edge (HSK) or on the side closing edge (NSK) depends on:

- distance: in between hinges (BD) and activation point of drive
- stroke or the opening width at the activation point of drive
- casement height

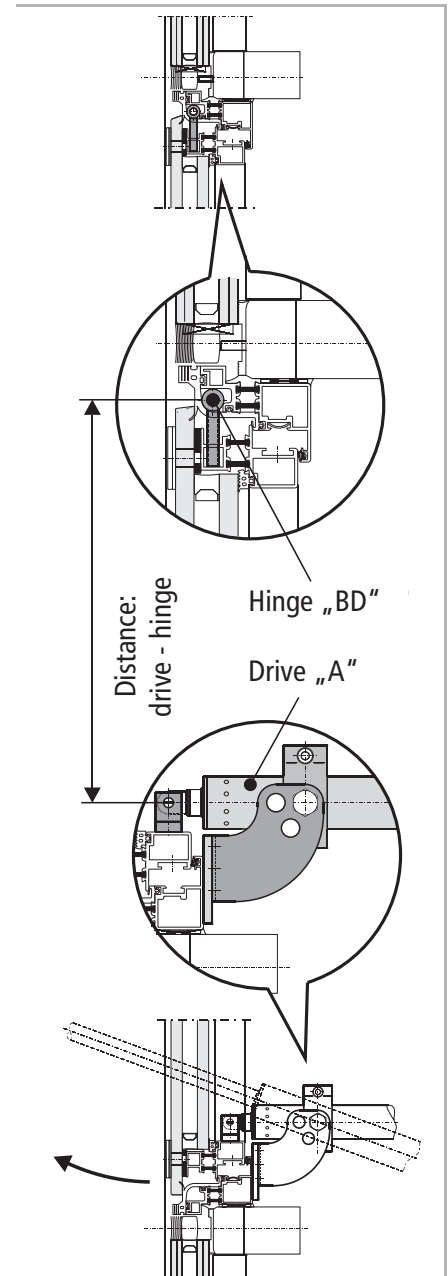
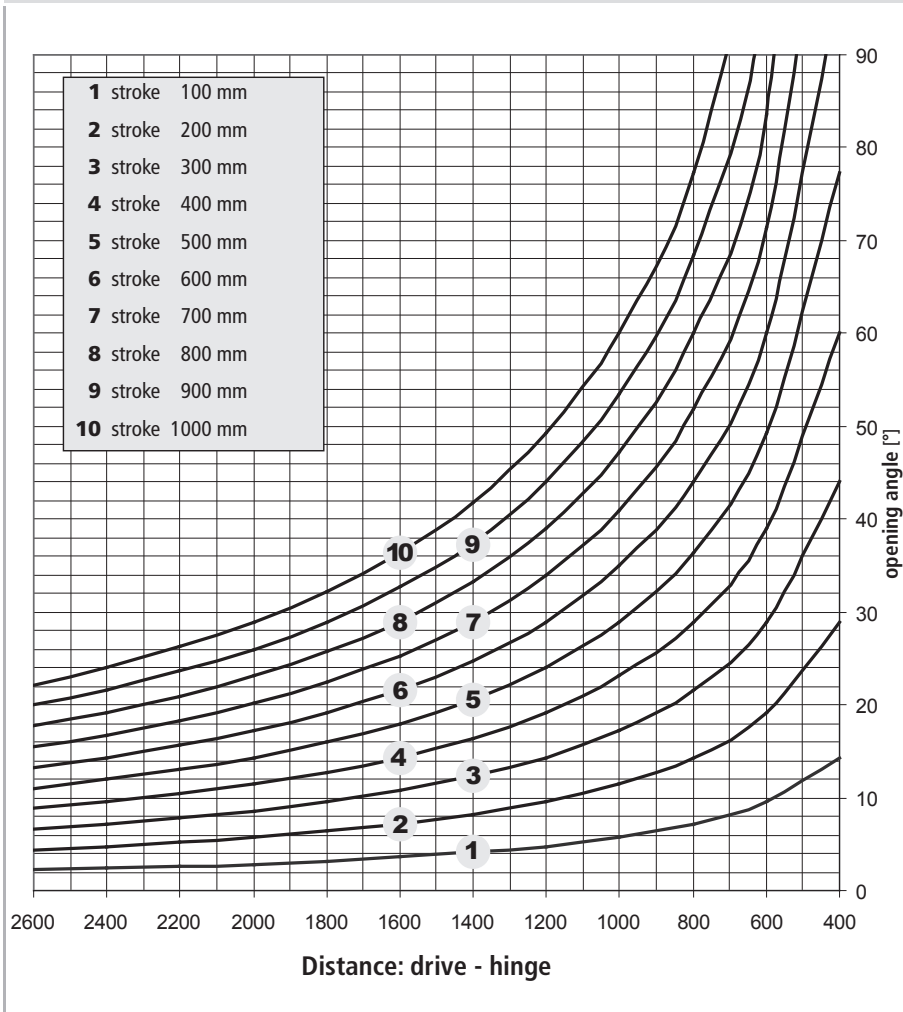



## INSTALLATION STEP 1: INSPECTION BEFORE THE INSTALLATION



### WARNING

Important instructions for a safe installation. Observe all instructions, wrong installation may result in serious injury!

### Storage of drives at the construction site

Protective measures against damages, dust, moisture or contamination shall be taken. Store drives intermediately only in dry and well ventilated rooms.

### Inspection of drives before installation

Check drives and window before installation for good mechanical condition and completeness. The chains / spindles of the drives must be extendable or retractable easily. The casement must run smoothly and the weight must be in balance.

The test procedure of drives may only be performed on a non-slip and secured mat or a test fixture. During the test run the test element must not be interfered with. The test may only be conducted by or under the supervision of expert personnel.

For testing chain drives the chain must be extended and retracted at an angle of approx. 90°. The spindle tubes of spindle drives in round housing tubes must be secured against independent spinning before starting the test to avoid deviations in the position encoder.

### Inspection of the intended use

The planned use of the drive must be checked for compliance with its intended use. If used otherwise the liability and warranty claim expires.

### Predictable misuse

It is imperative that foreseeable misuse of drives is avoided! Here are a few examples:

- do not connect 24 V DC drives to a 230 V AC mains voltage,
- observe synchronous run and sequence control by drives with multiple interconnection,
- use drives only indoors,
- avoid additional force influences, e.g. transverse forces.

### Testing mechanical requirements

Prior to the start of the installation check whether :

- the support surface and the profile static for the load transmission is sufficient,
- a support construction for the secure fastening of the drives is required,
- cold bridges (thermal separation) are avoidable at action points,
- there is sufficient space for the swivel movement of the drive.

If not, counter measures must be taken!



The support surface of the frame brackets or casement brackets must rest completely on the window or frame profile. There must be no tilting of the fastening elements during extension and retraction of the drives. A safe and solid fastening must be ensured at the window profile.



### CAUTION

It is imperative that the sufficiently mechanical stiffness of the fastener type as well as of the swivel range of the drive is observed.

If this is not guaranteed another type of fastening or another type of drive must be selected.

## INSTALLATION STEP 2: INSTALLATION PREREQUISITE AND INSTALLATION PREPARATION

The following conditions must be fulfilled for the installation of the drives so they can be properly assembled with other parts and constructed to a complete machine at the window without impairing the safety and health of persons:

1. The design of the drive must fulfill the requirements.
2. The fastening accessories (casement brackets or frame brackets) must fit the window profile; the profile-dependent hole lay-out must be complied with.
3. The space required for the installation of the drive on the frame and casement profile must be sufficient.
4. The window must be in perfect mechanical condition before the installation. It should open and close easily.
5. The fastening material for the installation of the drive must fit the window material (see table).

Wood windows	<p><u>wood screws:</u> i.e. DIN 96, DIN 7996, DIN 571</p> <p><u>with head-type:</u> round head with slot, round head with cross, hex head, special type</p>	
steel, stainless steel, aluminum windows	<p>self-tapping screws, thread screws, sheet-metal screws i.e. ISO 4762, ISO 4017, ISO 7049, ISO 7085, DIN 7500</p> <p><u>with head-type:</u> cylinder head with hex socket, internal serration (Torx), Phillips head or external hex head</p> <p>blind rivet nut</p>	
plastic windows	<p>screws for plastic i.e. DIN 95606, DIN 95607, ISO 7049, ISO 7085, DIN 7500</p> <p><u>with head-type:</u> round head with cross, external hex head, Torx</p>	<p><u>Recommendation:</u> if possible, screw through two cavity webs</p>

### Tools required

- Marker,
- Grains,
- Hammer,
- Knife,
- Screwdriver (cross, Torx),
- Hexagonal wrench,
- Torque wrench,
- Power drill,
- Threadlock adhesive,
- possibly a tool for blind rivet nuts.

### Check window data on site

- Measure FAB and FAH.
- Check / calculate weight of casement.  
If unknown, it can be determined approximately with the following formula:

$$G \text{ (Casement weight) [kg]} = \frac{\text{FAB [m]} \cdot \text{FAH [m]} \cdot \text{Glass thickness [mm]} \cdot 2,5 \cdot 1,1}{\text{glass-density} \cdot \text{frame share}}$$

- Check / calculate the required drive force and compare with drive data. If unknown, it can be determined approximately with the following formula:

$$F \text{ [N]} = \frac{5,4 \cdot G \text{ [kg]} \cdot s \text{ [m]}}{a \text{ [m]}}$$

Facade

$$F \text{ [N]} = \frac{5,4 \cdot G \text{ [kg]} \cdot \text{FAH [m]}}{a \text{ [m]}}$$

Roof

a = Distance of action point to hinges

F = Drive force

s = Stroke

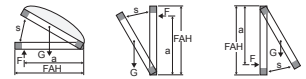

### Scope of delivery:

Prior to assembly, check items quantity in the delivery for completeness.

<b>Accessories for Spindle Drive</b>	
	<p>Assembly and Commissioning Instructions</p>
	<p>Warning sign sticker „Risk of entrapment“ (1x)</p>

### Positioning of the drives at the HSK

Positioning of the drives at the HSK		HSK
One Spindle Drive	Two Spindle Drive	

**INSTALLATION STEP 3A: DETERMINE THE CASEMENT BRACKETS**

**HSK** **NSK**

Hole layout for casement brackets

Casement bracket F10.8 S	Casement bracket F10.10	Casement bracket F11ST / F11VA
<p><b>HSK</b></p> <p>Suspension with bore Ø 8 mm</p>	<p><b>HSK</b></p> <p>Suspension with bore Ø 8 mm</p>	<p><b>NSK</b></p> <p>Suspension with bore Ø 8 mm</p>
Casement bracket F28	Casement bracket F28-1	Casement bracket F30
<p><b>HSK</b></p> <p>HEROAL 085D</p> <p>Suspension Ø 10 mm - Mounting with K121</p>	<p><b>HSK</b></p> <p>HEROAL 085D</p> <p>Suspension Ø 10 mm - Mounting with K82-1</p>	<p><b>NSK</b></p> <p>WICONA Wictec 50</p> <p>Suspension Ø 8 mm - Mounting with K121-1</p>
Casement bracket F36	Casement bracket F40	Support B2
<p><b>NSK</b></p> <p>SCHÜCO AWS 57RO</p> <p>Suspension Ø 8 mm - Mounting with K121-1</p>	<p><b>HSK</b></p> <p>Suspension with bore Ø 8 mm</p>	<p><b>HSK</b></p> <p>Mounting with casement bracket F 40</p>

INSTALLATION STEP 3B: DETERMINE THE FRAME BRACKETS

HSK NSK

Hole layout for frame brackets

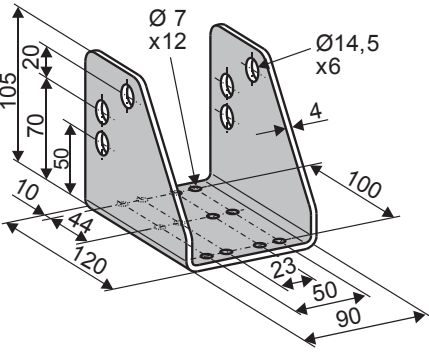
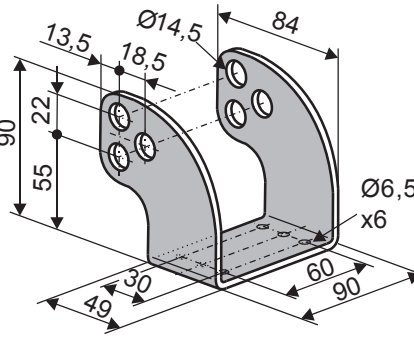
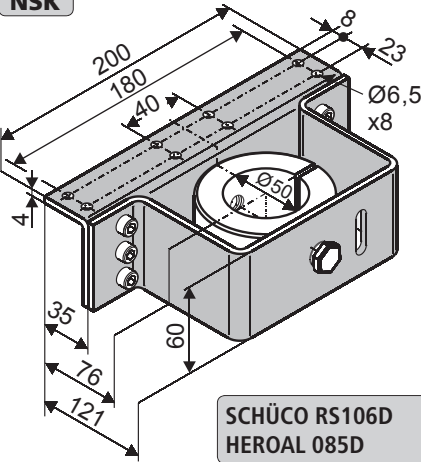
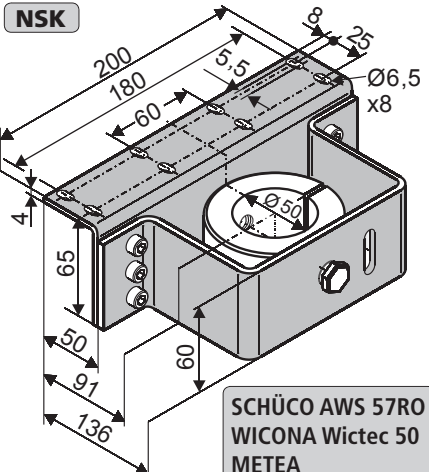
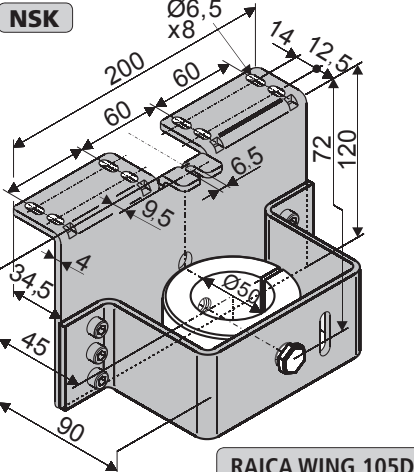
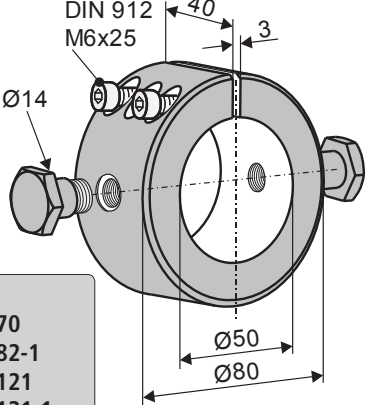
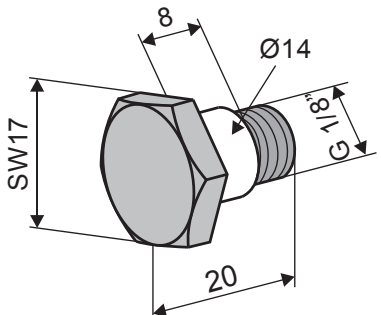
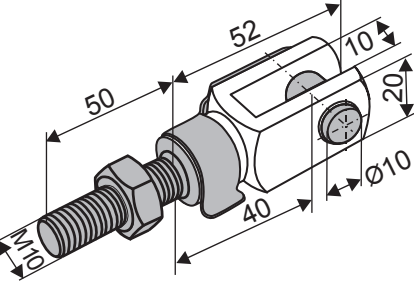
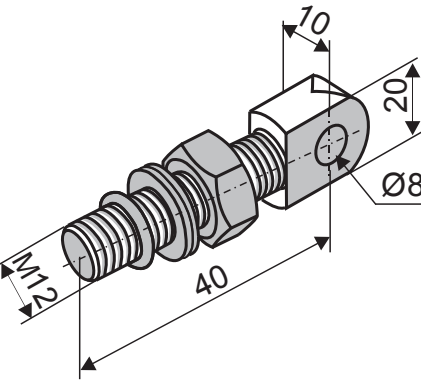
Frame bracket K70	Frame bracket K82-1	Frame bracket K121
<p><b>HSK</b></p>  <p>for swivelling suspension mounting with B6</p>	<p><b>HSK</b></p>  <p>for swivelling suspension mounting with B6</p>	<p><b>NSK</b></p>  <p>SCHÜCO RS106D HEROAL 085D</p> <p>for swivelling suspension mounting with B6</p>
Frame bracket K121-1	Frame bracket K127-1	Verstellbare Klemmbefestigung B6
<p><b>NSK</b></p>  <p>SCHÜCO AWS 57RO WICONA Wictec 50 METEA</p> <p>for swivelling suspension mounting with B6</p>	<p><b>NSK</b></p>  <p>RAICA WING 105D</p> <p>for swivelling suspension mounting with B6</p>	 <p>DIN 912 M6x25</p> <p>For:</p> <ul style="list-style-type: none"> <li>• K70</li> <li>• K82-1</li> <li>• K121</li> <li>• K121-1</li> <li>• K127-1</li> </ul> <p>for swivelling suspension</p>
Collar screw B9	Clevis B28ST	Eye bolt B29ST
 <p>for adjustable clamping B6</p>	 <p>with M10 thread</p>	 <p>with M12 thread</p>

INSTALLATION STEP 4A: HOLE LAYOUT: ACTIVATION ON HSK

System: HEROAL 085D

Roof window - outward opening - Frame assembly - HSK

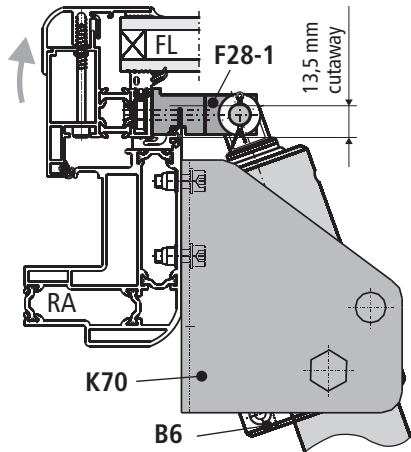

Top view - Drilling

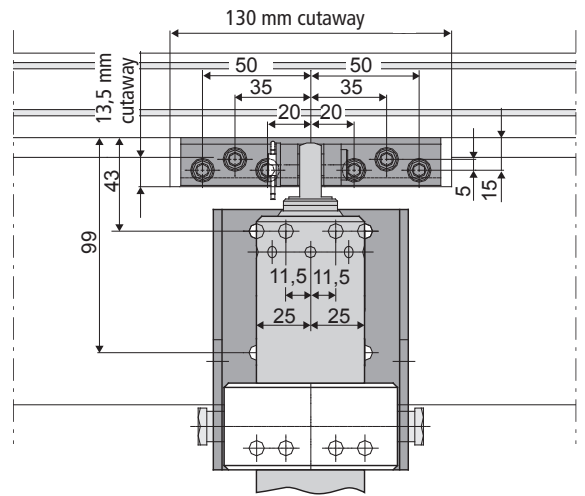

System: SCHÜCO AWS 70

Top-hung casement - outward opening - Frame assembly - HSK

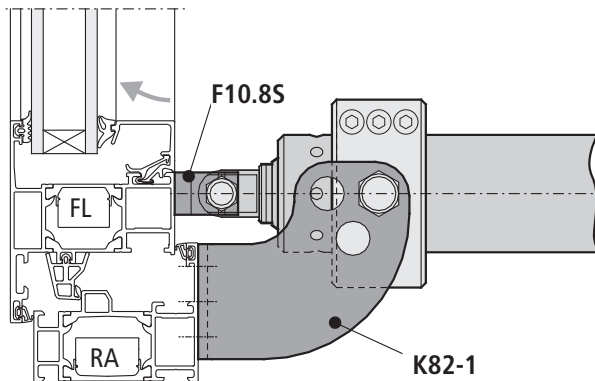

Top view - Drilling

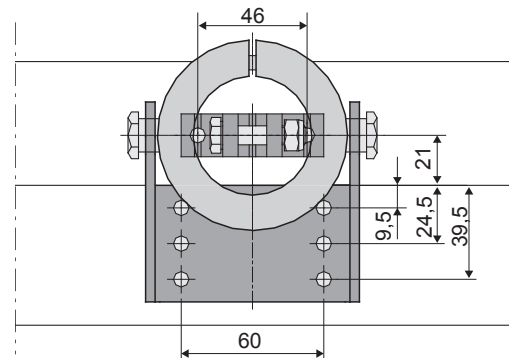

System: SCHÜCO AWS 57R0

Roof window - outward opening - Frame assembly - HSK

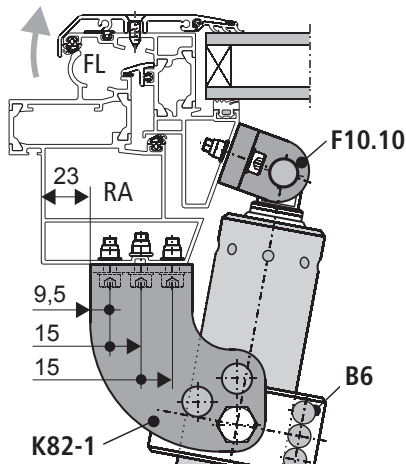

Top view - Drilling

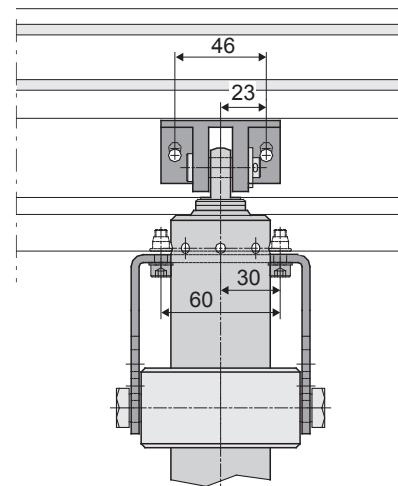

HOLE LAYOUT: ACTIVATION ON HSK



System: HEROAL 085D

Roof window - outward opening - Frame assembly - HSK

Top view - Drilling

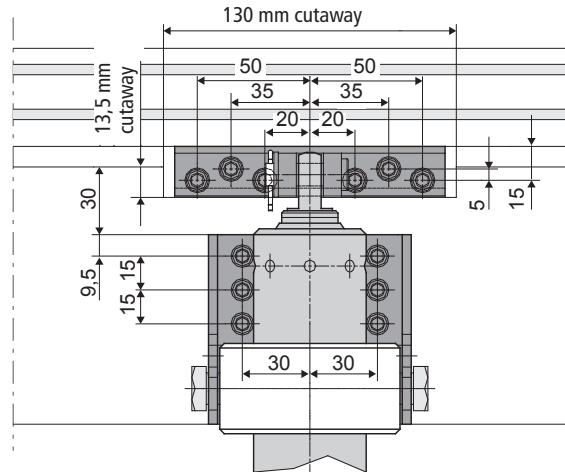
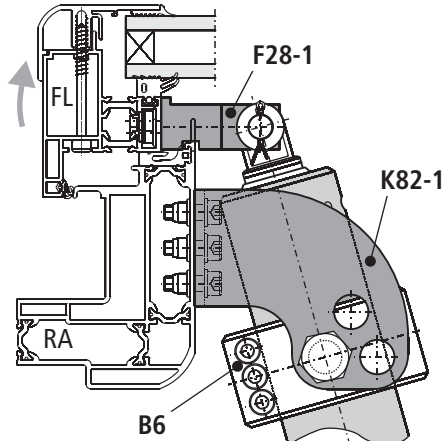

Top view

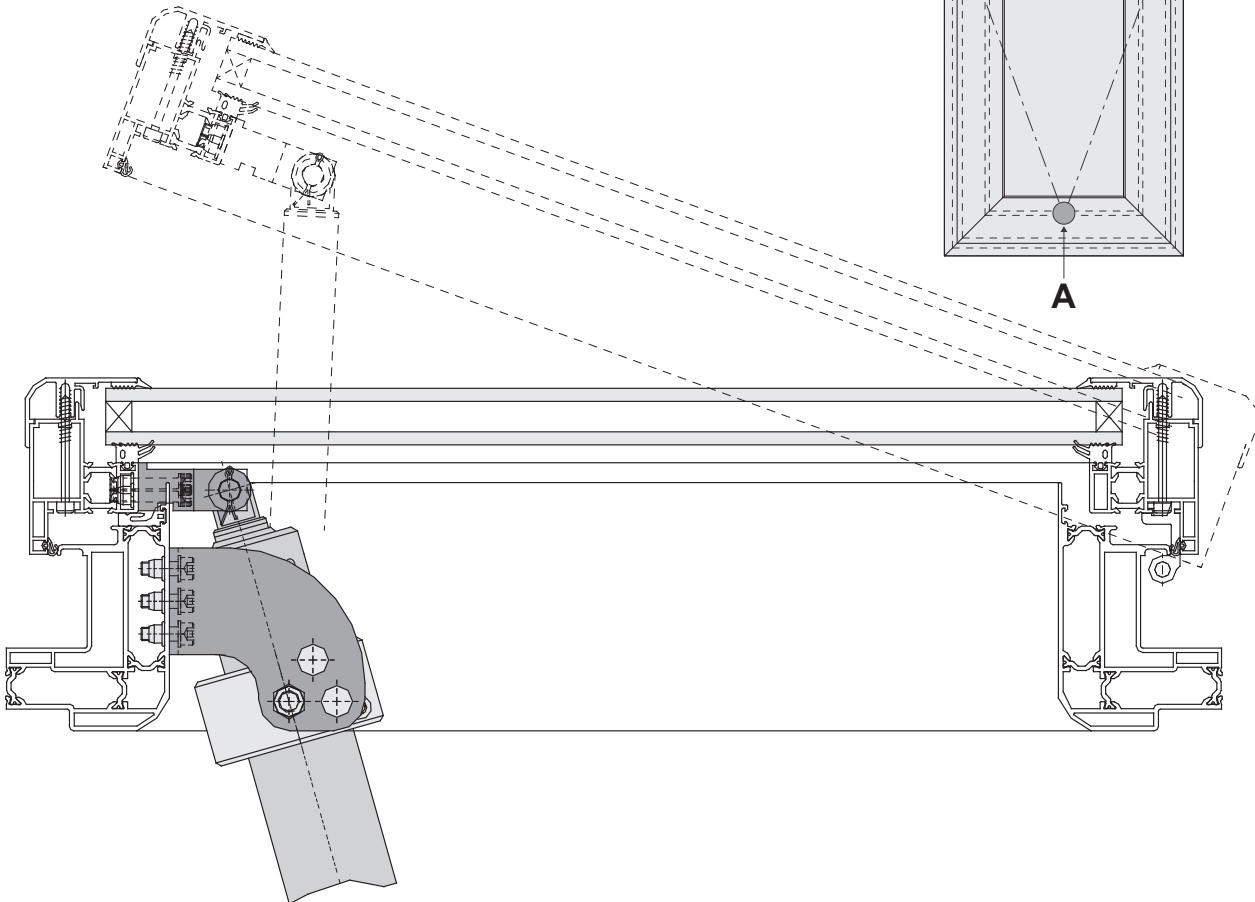
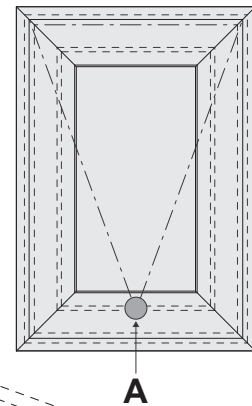

**INSTALLATION STEP 4B: HOLE LAYOUT: ACTIVATION ON NSK**

**System: HEROAL 085D**

Roof window - outward opening - Frame assembly - NSK

Top view - Drilling

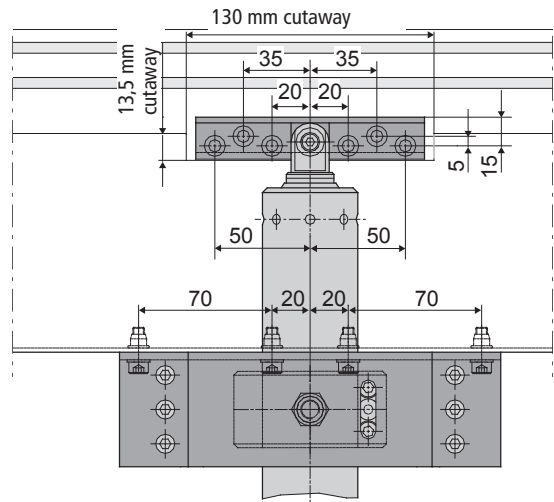
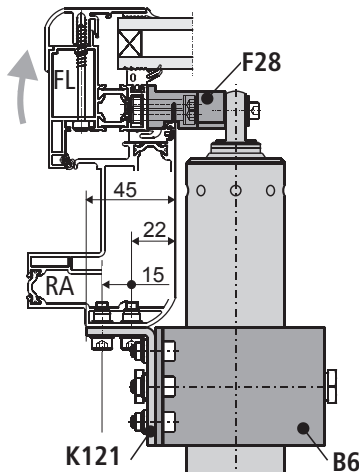

**System: SCHÜCO AWS 57R0**

Roof window - outward opening - Frame assembly - NSK

Top view - Drilling

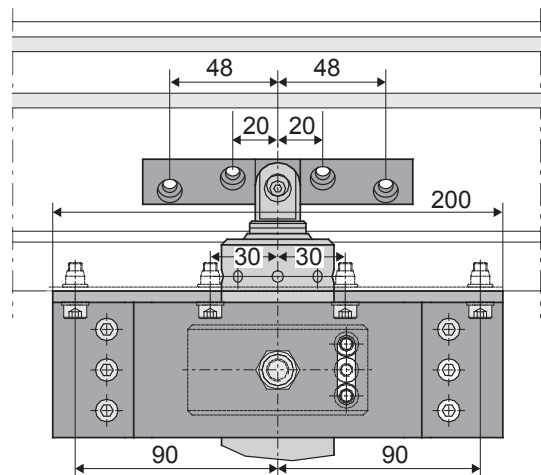
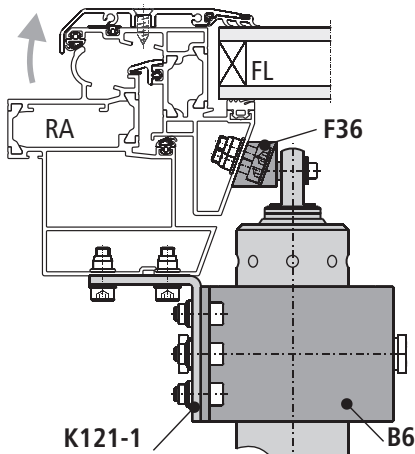

**System: WICONA Wictec 50**

Roof window - outward opening - Frame assembly - NSK

Top view - Drilling

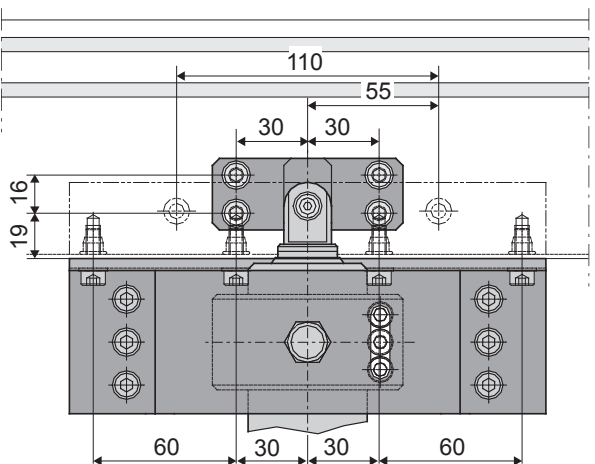
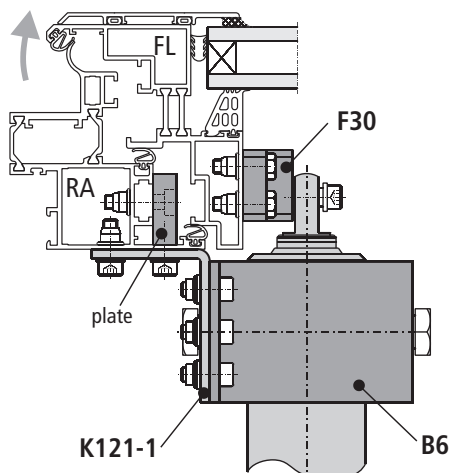

HOLE LAYOUT: ACTIVATION ON NSK



System: RAICO Wing 105D

Roof window - outward opening - Frame assembly - NSK

Top view - Drilling

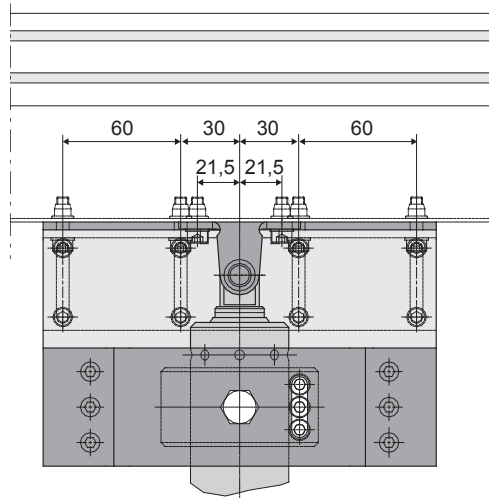
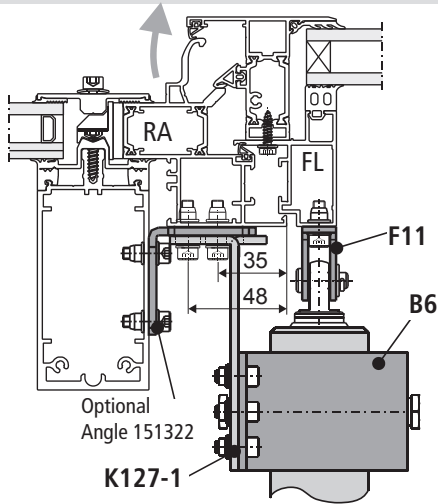

Top view

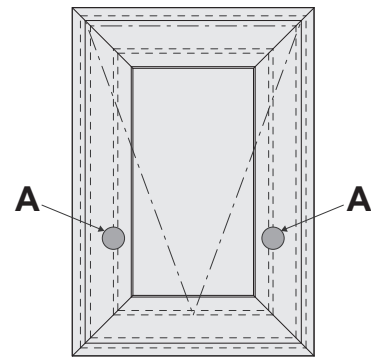
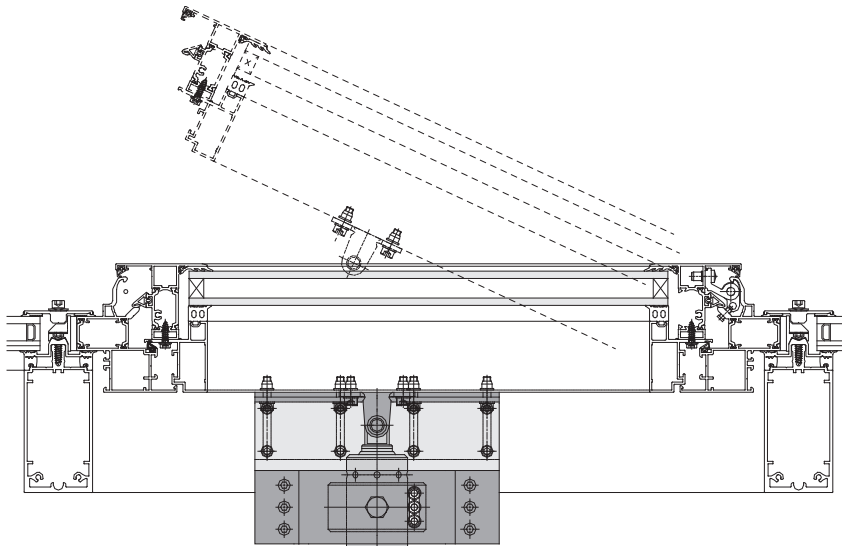

INSTALLATION STEP 4c: SKY LIGHT



Sky light system: Eternit Fumilux4000

Sky light  
Frame assembly - HSK

Sky light  
Frame assembly - solo

Sky light  
Frame assembly - tandem

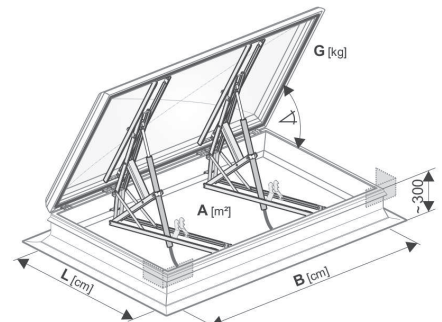
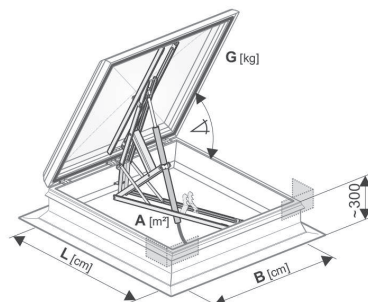
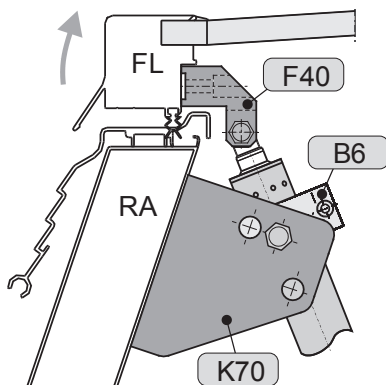



# INSTALLATION STEP 5A: ASSEMBLY FOR DIRECT OPERATION - ACTIVATION ON HSK (OUTWARD OPENING)

- Determine fastenings.
- Produce drill holes with appropriate cross-section. For the mounting dimensions please refer to the above-mentioned hole layout drawings (see chapter „INSTALLATIONSTEP 3 + 4“) or project-specific documents and drawings).

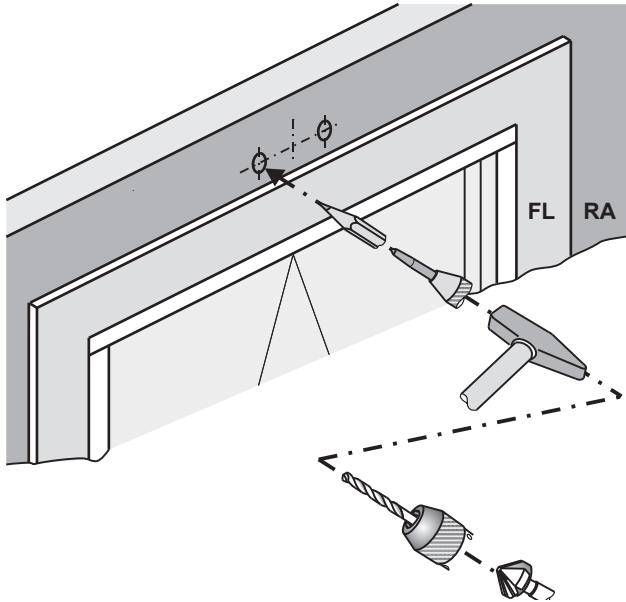

Carefully clear away drilling swarfs to prevent seals from being damaged. Avoid surface scratches, for example by using masking tape.

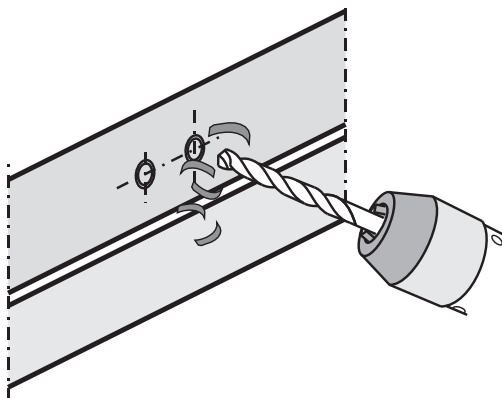

- Secure fasteners against loosening; i. e. by applying removable thread-locking compound such as "Loctite".

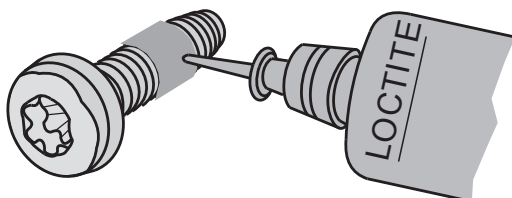

- Fit casement bracket **F10.8S** ①.



Make sure it is parallel to casement edge. „Casement bracket“ center and „spindle“ must be in line.

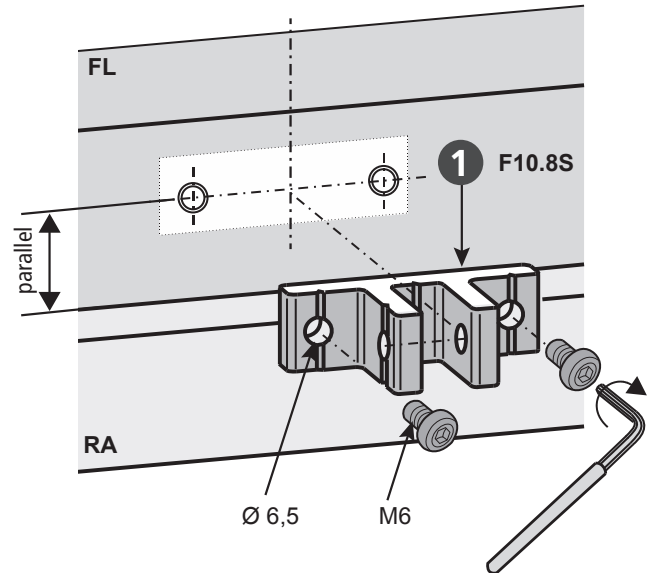

- Fit frame bracket **K82-1** ②.



Make sure they are parallel to casement edge.

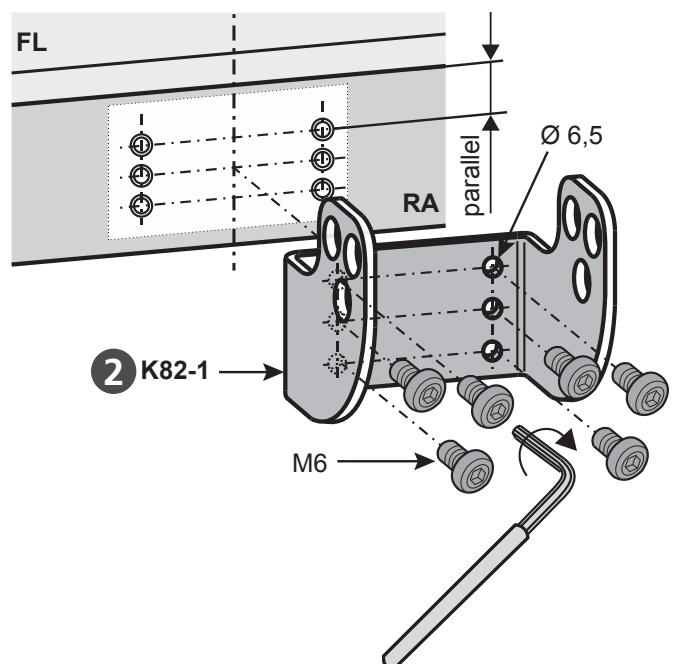

- Untighten the cylinder head screw M6 ⑤ from the adjustable clamping B6 ③.
- To facilitate insertion of the drive in the adjustable clamping B6 ③, screw in a third screw M6 in the middle threaded hole.
- Slide the adjustable clamping B6 ③ gently on the body by hand (do not force). Adjust the accurate positioning according to the site conditions. Tighten the screws M6 ⑤ easily.

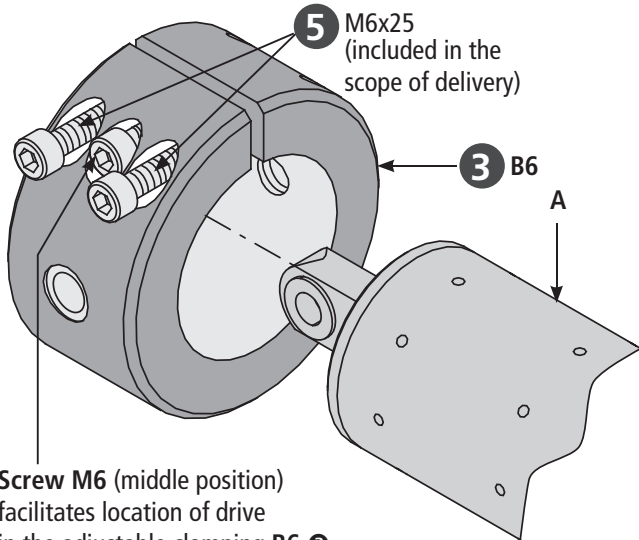

Screw M6 (middle position) facilitates location of drive in the adjustable clamping B6 ③. Remove this screw after assembly.

**NOTE** Center screw M6 is not included in the scope of delivery.

- Attach drive with adjustable clamping B6 ③ to frame bracket K82-1 ②.
- Screw in the collar screw ④ and tighten to a maximum of 15 Nm.

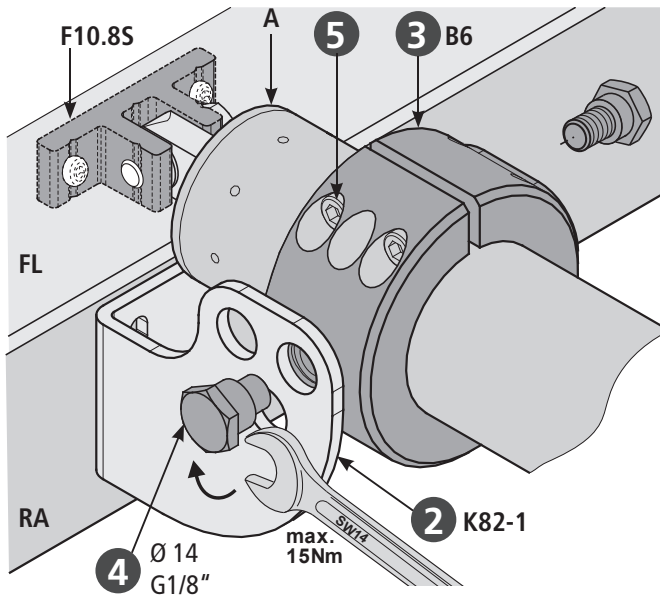

**Equipment: Adjustable clamping B6 ③**

④	2x collar screw Ø 14, G1/8"
⑤	2x cylinder head screw M6x25

- Attach drive to casement bracket F10.85 ①.
- Insert screw M8x35 ⑥ and tighten with even secure nut M8 ⑦.

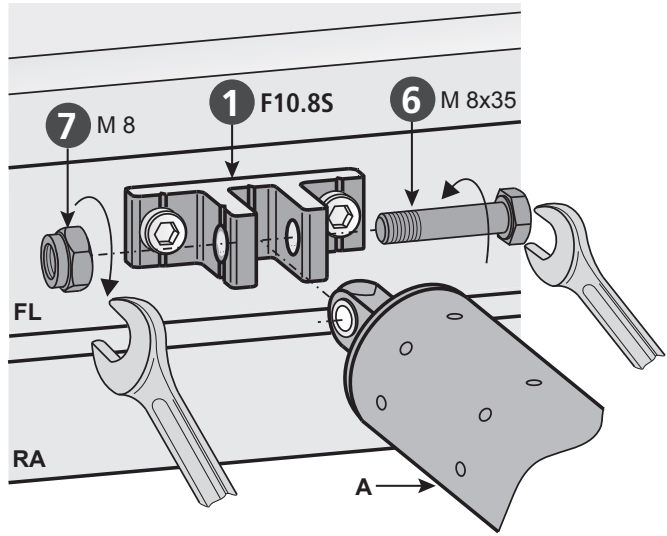

**Equipment: Casement bracket F10.85 ①**

⑥	1x screw M8x35
⑦	1x even secure nut M8, with polyamide clamping part

- Adjust casement pressure. Tighten the cylinder head screw M6 ⑤ from the adjustable clamping B6 ③ to torque of 10 Nm Drehmoment.

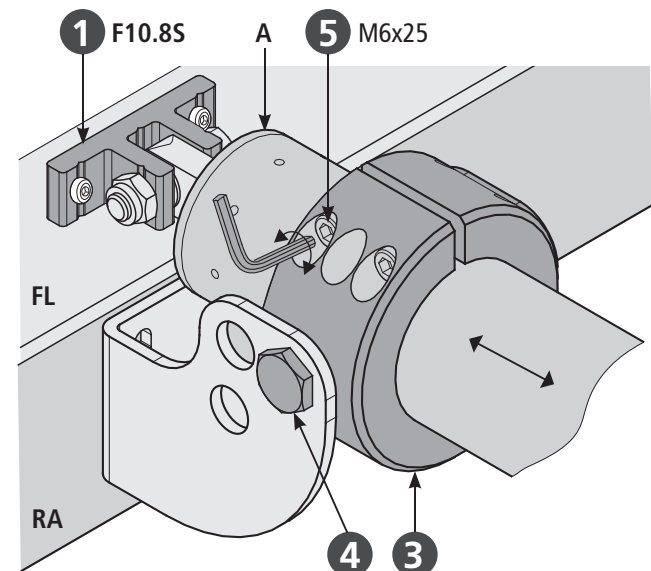

### INSTALLATION STEP 5B: ASSEMBLY FOR SIDE-CLOSING EDGE OPERATION - NSK

- Determine fastenings.
- Produce drill holes with appropriate cross-section. For the mounting dimensions please refer to the above-mentioned hole layout drawings (see chapter „INSTALLATIONSTEP 3 + 4“) or project-specific documents and drawings).

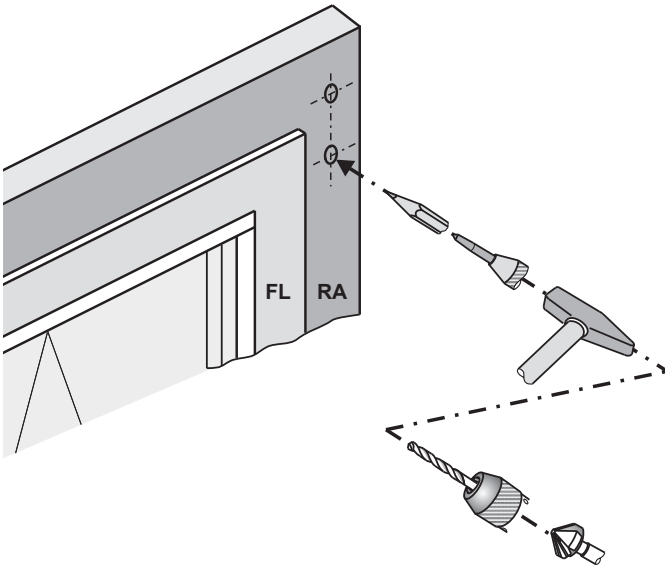

Carefully clear away drilling swarfs to prevent seals from being damaged. Avoid surface scratches, for example by using masking tape.

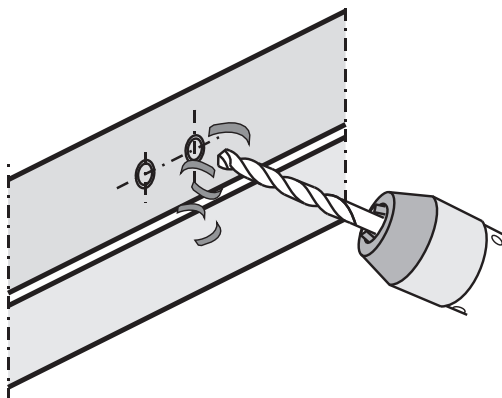

- Secure fasteners against loosening; i. e. by applying removable thread-locking compound such as "Loctite".

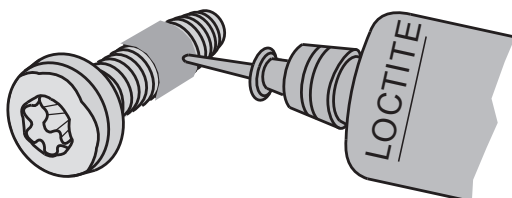

- Fit casement bracket F11/ST / F11VA ①.



Make sure it is parallel to casement edge. „Casement bracket“ center and „spindle“ must be in line.

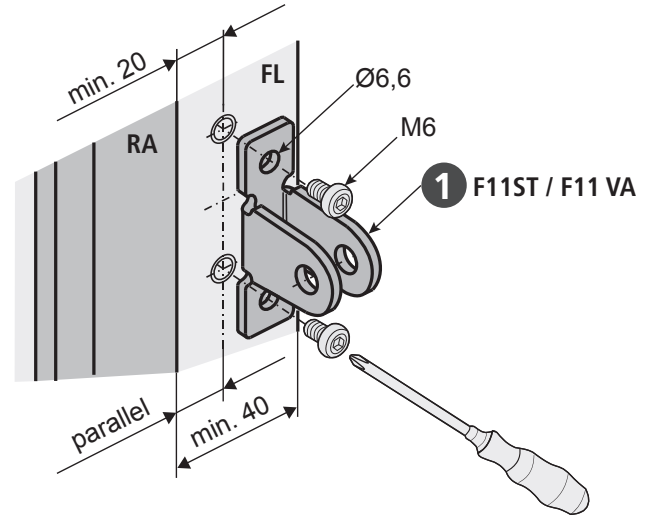

#### Equipment: Casement bracket F11ST / F11VA ①

④	1x bolt Ø8
⑤	1x washer
⑥	1x cotter pin

- Fit frame bracket K127-1 ②.



Make sure they are parallel to casement edge.

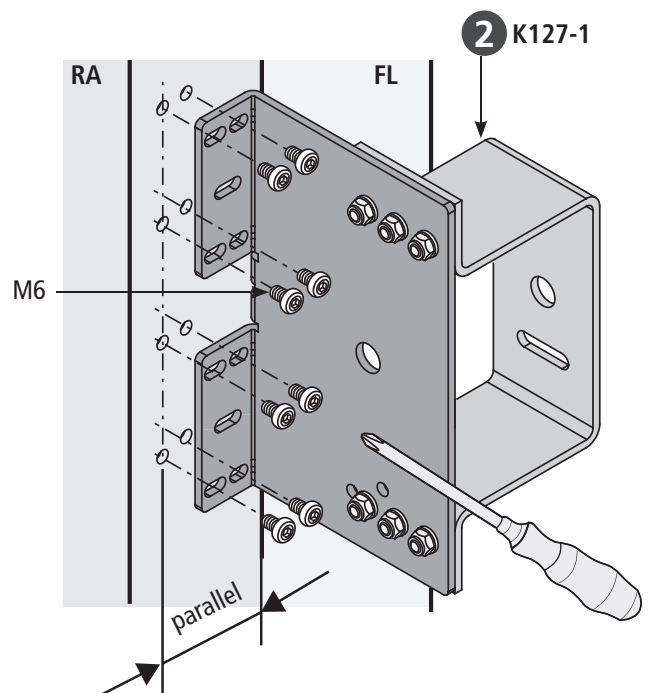

- Untighten the cylinder head screw M6 ⑧ from the adjustable clamping B6 ③.
- To facilitate insertion of the drive in the adjustable clamping B6 ③, screw in a third screw M6 in the middle threaded hole.
- Slide the adjustable clamping B6 ③ gently on the body by hand (do not force). Adjust the accurate positioning according to the site conditions. Tighten the screws M6 ⑧ easily.

**Screw M6 (middle position)** facilitates location of drive in the adjustable clamping B6 ③. Remove this screw after assembly.

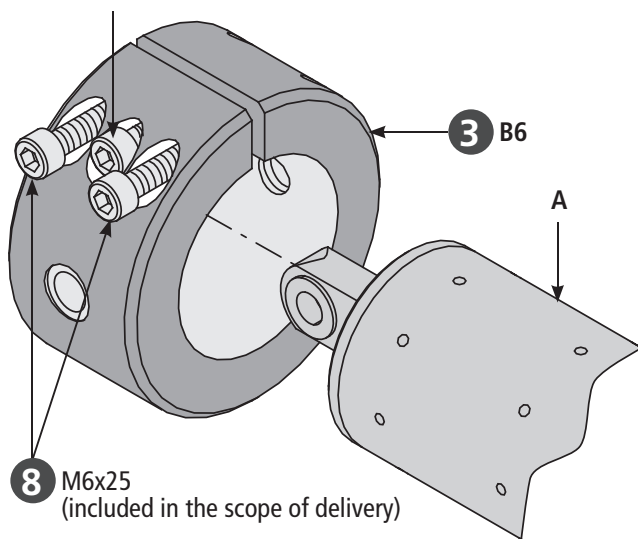

**NOTE** Center screw M6 is not included in the scope of delivery.

Equipment: Adjustable clamping B6 ③	
	⑦ 2x collar screw Ø 14, G1/8"
	⑧ 2x cylinder head screw M6x25

- Insert the drive with the installed adjustable clamping B6 ③ in the frame bracket K127-1 ②.
- Screw in the collar screw ⑦ and tighten to a maximum of 15 Nm.



Ensure to align to the casement bracket ①.

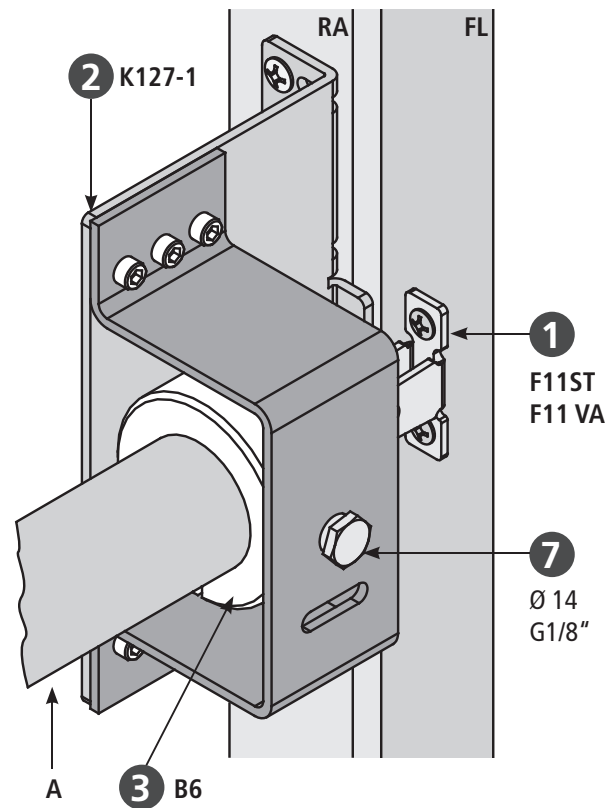

- Insert drive to the casement bracket F11/ST / F11VA ①.
- Attach drive with bolt ⑤.
- Secure bolt ⑤ with washer ⑥ and cotter pin ⑦.
- Spread out the cotter pin ⑦.

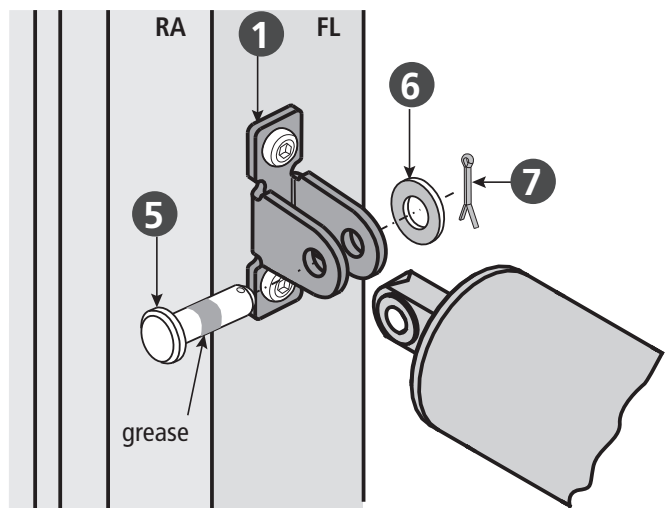

- Adjust casement pressure. Tighten the cylinder head screw M6 ⑧ from the adjustable clamping B6 ③ to torque of 10 Nm.

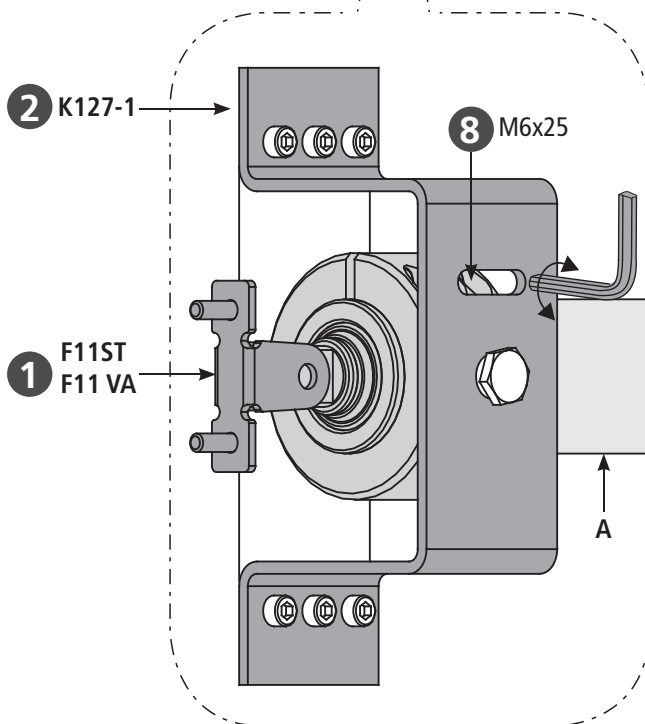
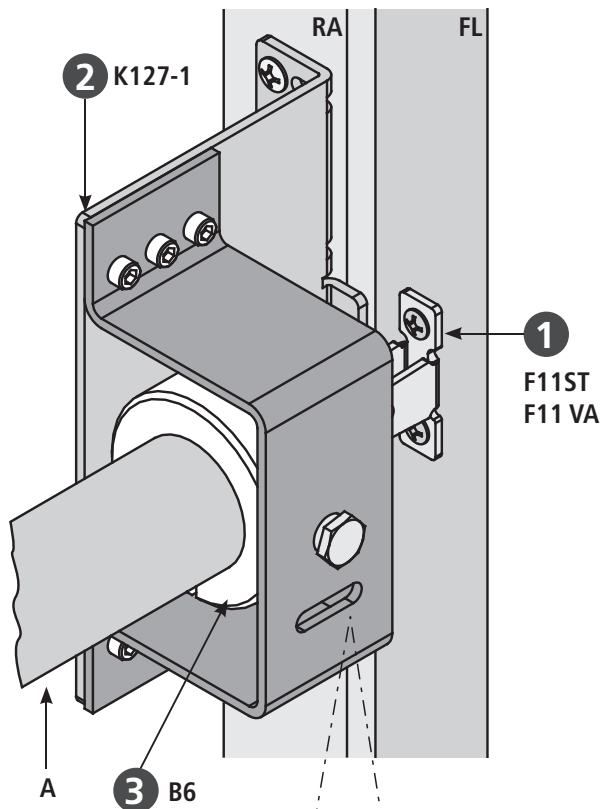

Window must be fully closed.

- To fit the second drive.

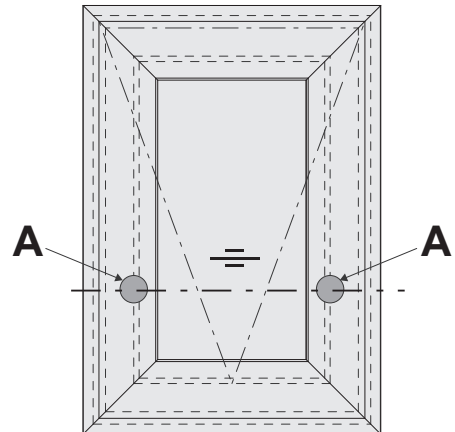

Fit both mounting bracket so that their axes are in line. Check contact pressure of casement.

**INSTALLATION STEP 6: ELECTRIC CONNECTION**

**HSK** **NSK**



Make sure when establishing the connection that there is no voltage at the terminals!  
Unused wires must be safely insulated!

The running direction of the drive may be changed by interchanging (polarity reversal) the wires „BN – (brown)” - „BU – (blue)”.



Drives must be switched by the controller to the opposite direction (pole reversed) when switched off at overload.

Wire colour coding		Direction of travel
Colour	DIN IEC 757	
black	BK	OPEN
white	WH	
brown	BN	CLOSE
blue	BU	
green / yellow	GN / YE	polarity reversal 
green	GN	
violet	VT	
grey	GY	

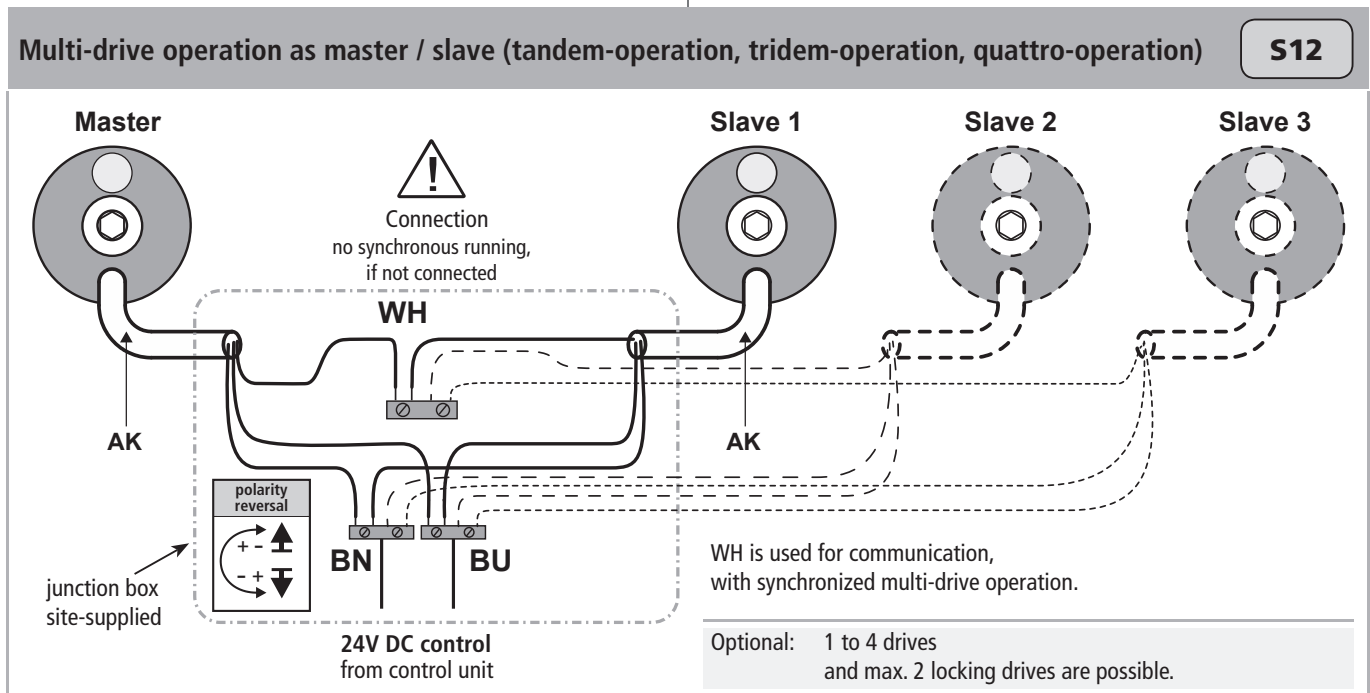
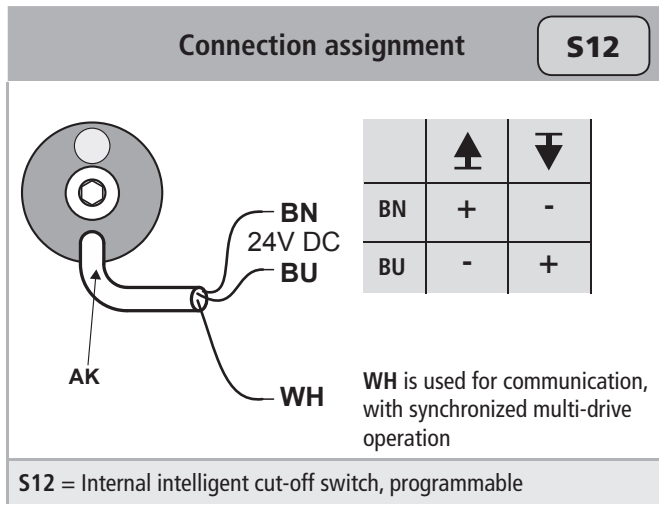

ELECTRIC CONNECTION

**Multi-drive operation with M-COM 24V**

drive 1

drive 2

AK

AK

WH

BN

BU

M-COM

24V DC control from control unit

junction box site-supplied

Connection  
no synchronous running,  
if not connected

polarity reversal

WH is used for communication,  
with synchronized multi-drive operation.

Optional: 1 to 4 drives  
and max. 2 locking drives are possible.

**M-COM (Main control unit) 24V**

**Order number:** 524177

**Application:** Main control unit for the automatic configuration and monitoring of max. 4 opening / 2 locking drives type S12 / S3 (software version SW-V2) in multi-drive systems.

**Rated voltage:** 24V DC +/- 20%, (max. 2 Vss)

**Current consumption:** <12 mA

**Drive type:** S12

**Protection class:** IP30 rubber jacket

**Ambient temperature:** 0 °C ... + 70 °C

**Dimensions:** 45 x 17 x 6 mm

**Connecting wires:** 3 wires 0,5 mm<sup>2</sup> x 50 mm

**Feature / Equipment:** printed circuit board with connecting wires for integration in site-supplied junction box.

**Cable junction box (for renewal) 24V**

**Order number:** 513344

**Application:** to extend a drive cable

**Rated voltage:** only for low voltage to max. 50V DC/AC

**Material:** stainless steel (V2A)

**Protection class:** IP 40

**Dimensions:** 25 x 27 x 150 mm

**Equipment:** with cable gland (grey) including strain relief, with loose ceramic terminals.

**UniPC with configuration interface 24V 230V**

**Order number:** 524178

**Application:** Hard- and software for configuration of drives supplied by Aumüller Automatic GmbH

**Rated voltage:** 24V DC +/-20%

**Parameterizable drives:** 24V DC type MP, S3, S12, S12 V.2  
230V AC type S12, S12 V.2

**Scope of delivery:** software UniPC (Downloadlink\*), Interface "ParInt", USB cable, connection cable

\* <http://www.aumueller-gmbh.de/Downloads>

**Features / Equipment:** Power supply 24V DC is not included in the scope of delivery! Any extended settings require a software licence.

Any reconfiguration of a drive is entirely at the user's own risk and responsibility.

## INSTALLATION STEP 7: SUPPLY LINES OF DRIVES TO THE CONTROL UNIT

Observe current regulations and guidelines e.g. DIN 4102-12 regarding the "Fire behavior of building materials-circuit integrity maintenance of electric cable systems" (E30, E60, E90) and the "Specimen Guideline on Conduits German designation - MLAR", and also prescribed constructional regulations!

**RECOMMENDATION** For safety reasons a cable of the next higher wire cross section should be selected.

### Formula to calculate

the required wire cross-section of a supply line

**24V**

$$A \text{ mm}^2 = \frac{I_{A \text{ (total)}} * L_m \text{ (length supply line)} * 2}{2,0^V \text{ (voltage drop)} * 56 \text{ m} / (\Omega * \text{mm}^2)}$$

### Calculation example

#### Available data:

- cut-off current per drive (i. e. 2 x 4.0A) from data sheet
- length to be bridged from the last window to the control unit (i. e. 10 meters)

$$A = \frac{(2 * 4,0A) * 10m * 2}{2,0V * 56m / (\Omega * \text{mm}^2)}$$

$$A = 1,42\text{mm}^2 \rightarrow 1,5\text{mm}^2 \text{ chosen}$$

## Laying and connecting the drive cable

- Avoid extreme temperature differences in the installation area (danger of condensation).
- Set clamping point close to window and ensure accessibility.
- Ensure expansion possibilities of the drive and the drive cable.
- Consider the cable length of drives.

## INSTALLATION STEP 8: SAFETY CHECK AND TEST RUN

Check the mounted system for its safety; perform test run and commissioning.

### Safety test:

- Connect operating voltage.
- Check fastening (frame brackets, casement brackets) for firm fit or tightening.

### Test run:

- Visual inspection of casement movements.
- Stop immediately by malfunction!
- Pay attention to collision with facade construction and correct installation, if required.

### Risk evaluation:

Before operating a power-operated window to which window drives were mounted, which were sold by the manufacturer as incomplete machines according to installation declaration, the possible risk to ahazard of persons must be determined, evaluated and minimized by taking appropriate technical measures in accordance with the Machinery Directive. Separate documents for performing a risk assessment can be downloaded from the homepage of

**Firm AUMÜLLER Aumatic GmbH**  
([www.aumueller-gmbh.de](http://www.aumueller-gmbh.de)).

## Operation of the power-operated window

When operating the power-operated window safety instructions must be observed, specifically those pertaining to commissioning, operation and maintenance.

## CONNECTION CABLE ROUTING **HSK** **NSK**

### Connection cable routing on the drive body

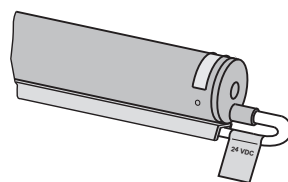

Cable duct glued on.

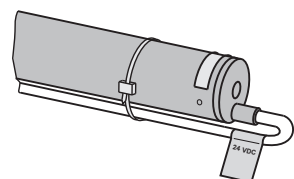

Attach connection cable with cable ties.



## HELP IN CASE OF MALFUNCTIONS, REPAIRS AND MAINTENANCE

Professional repair of a defect drive can only be performed at the manufacturer's factory or manufacturer-certified specialist company. Unauthorized opening or manipulation of the drive terminates warranty.

1. Exchange defect drives or have them repaired by the manufacturer.
2. In case of problems during installation or normal operation the following table might be useful:

Problem	Possible causes	Possible solutions
<b>Drive does not start</b>	<ul style="list-style-type: none"> <li>• Duration of mains power supply too short</li> <li>• Drive run direction not correct</li> <li>• Connecting cable not connected</li> <li>• Power supply / Control Unit voltage incorrect, too high or too low (see data sheet)</li> <li>• No mains supply to power supply unit / Control Unit (no voltage)</li> <li>• Drive has shut down on overload</li> </ul>	<ul style="list-style-type: none"> <li>• Adjust supply voltage as specified in the technical documentation</li> <li>• Check drive cables change polarity</li> <li>• Check all connection cables</li> <li>• Check power supply unit and replace if necessary</li> <li>• Connect power supply</li> <li>• First move drive in CLOSE position</li> </ul>
<b>Drive doesn't start after having been in operation several times</b>	<ul style="list-style-type: none"> <li>• Operating time has been exceeded, drive has been overheated</li> <li>• See possible solutions above associated with „Drive doesn't start“</li> </ul>	<ul style="list-style-type: none"> <li>• Wait until drive has cooled down and start again</li> <li>• See possible solutions associated with: "Drive doesn't start"</li> </ul>

## MAINTENANCE AND MODIFICATION

To ensure continuous function and safety of the drive periodic maintenance by a specialist company is required at least once a year (as mandated by law for smoke and heat exhaust systems). Operational readiness must be checked regularly. Frequent inspection of the system for imbalance and signs of wear or damages of cables and fastening elements must be performed.

During maintenance contaminations must be removed from the drive. Fastenings and clamping screws must be checked for tightness. Test runs during the opening and closing procedure of the devices must be performed.

The drive itself is maintenance-free. Defect devices may only be repaired in our factory. Only replacement parts of the manufacturer may be used. When the connection cable of this device is damaged it must be replaced by the manufacturer or his customer service or a similarly qualified person to avoid endangerment.

It is recommended to conclude a maintenance contract. A sample maintenance contract can be downloaded from the homepage of **Firm Aumüller Aumatic GmbH** ([www.aumueller-gmbh.de](http://www.aumueller-gmbh.de)).

While cleaning the windows, drives may not have direct contact with water or cleaning agents. Drives must be protected from dirt and dust during the construction phase or renovations.

### Maintenance process

1. Open or extend power-operated casement completely.
2. Completely disconnect the system from the mains and secure it against automatic or manual activation.
3. Check windows and fittings for damages.
4. Check all mechanical fastenings (if required, observe information on torques in installation instructions).
5. Check electric drives for damages and contaminations.
6. Check connecting cables (drive cable) for:
  - tightness of the cable screw
  - functionality of the strain relief
  - damages
7. Check the mobility of hinges and fittings and re-adjust or apply lubricant, e.g. silicone spray (observe the instructions of the manufacturer of this window system).
8. Check peripheral seal, remove contaminations or replace.
9. Perform cleaning to maintain functionality (e.g. clean extending elements of the drive, such as chains or spindles by damp wiping them with acid or lye-free agents and drying them and, if required, lubricate them with cleansing oil e.g., Ballistol).
10. Turn on operating voltage.
11. Open and close the power-operated window via the operating voltage (functional test).
12. If available, check and re-adjust protection systems of the safe guard fixture.
13. Check the intactness of the CE label at the power-operated system (e.g. SHEV/Natural smoke and heat exhaust ventilators).
14. Check the intactness of warning instructions and labels at the respective drive.
15. Perform a risk assessment in accordance with Machinery Directive 2006 / 42 / EG, if required, e.g. after modifying the machine.

## DEMOUNTING AND DISPOSAL

The drives are demounted by reversing the steps, as for the installation. The adjustments are omitted.

1. Completely disconnect the system from the power supply before demounting a drive.
2. After demounting a drive the window must be secured against independent opening.

Dispose of parts according to the locally applicable legal provisions.

## LIABILITY

We reserve the right to change or discontinue products at any time without prior notice. Illustrations are subject to change. Although we take every care to ensure accuracy, we cannot accept liability for the content of this document.

## WARRANTY AND CUSTOMER SERVICE

In principal apply our:

**„General Terms for the Supply of Products and Services of the Electrical Industry (ZVEI)“.**

The warranty corresponds with legal provisions and applies to the country in which the product has been acquired.

The warranty includes material and manufacturing defects incurred during normal use.

The warranty period for delivered material is twelve months.

Warranty and liability claims for personal injuries or material damages are excluded, if caused by one or more of the following:

- Improper use of the product.
- Improper installation, commissioning, operation, maintenance or repair of the product.
- Operating the product by defect and improper installed or not functioning safety and protection devices.
- Ignoring instructions and installation requirements in these instructions.
- Unauthorized constructional modifications at the product or accessories.
- Disaster situations due to effects of foreign bodies and Acts of God.
- Wear and tear.

Point of contact for possible warranty claims or for repair parts or accessories is the responsible branch office or the responsible person at

**Firm AUMÜLLER Aumatic GmbH.**

Contact data are available at our homepage

**([www.aumueller-gmbh.de](http://www.aumueller-gmbh.de))**

## KONFORMITÄTSERKLÄRUNG DECLARATION OF CONFORMITY

Hersteller  
Manufacturer

**aumüller**

Aumüller Aumatic GmbH  
Gemeindewald 11  
86672 Thierhaupten  
Germany

Produktart | *Product type*: **Spindelantriebe für Fenster** | *Spindle drives for windows*  
Produktbaureihe | *Product series*: **PLS 15 / 30 / 50 xxxx S12 - 24V**

Ab Seriennummer | *From serial number*: **XXXXXX-XX-XXX**

Ab Datum | *From date*: (Year-W-Week) **16W10**

Wir bestätigen die Konformität des oben bezeichneten Produktes mit folgend gelisteten EU-Richtlinien sowie Normen:  
*We herewith confirm the conformity of the above mentioned product with EC Directives and the standards listed below:*

### KONFORMITÄT CONFORMITY

#### Richtlinie über elektromagnetische Verträglichkeit 2014/30/EU

*Directive relating to Electro-Magnetic Compatibility 2014/30/EU*

#### Niederspannungsrichtlinie 2014/35/EU

*Low Voltage Directive 2014/35/EU*

### HARMONISIERTE NORMEN

HARMONIZED STANDARDS

**DIN EN 60335-2-102:2016-05**

**DIN EN 61000-6-1:2007-10**

**DIN EN 61000-6-2:2006-03**

**DIN EN 61000-6-3:2011-09**

**DIN EN 61000-6-4:2011-09**

### SONSTIGE TECHNISCHE NORMEN UND SPEZIFIKATIONEN

FURTHER TECHNICAL STANDARDS AND SPECIFICATIONS

**DIN EN 12101-2:2003-09** (PLS 15 / 30 in ferralux® NRWG - 24 V DC)

**Montageanweisung** | *Installation instructions*

Thierhaupten, 01.03.2016

*R. Meinzer*

Geschäftsführer / Verantwortlich für die technische Dokumentation  
Managing Director / Head of technical documentation



**Die Sicherheitshinweise der mitgelieferten Produktdokumentation sind zu beachten!**

**The safety instructions of the supplied product documentation are to be observed!**

Zertifikat Certificate

VdS Schadenverhütung  
 bescheinigt die Anwendung eines  
**Qualitätsmanagementsystems**  
 für



**aumüller**

Aumüller Aumatic GmbH · Gemeindewald 11 · D-86672 Thierhaupten

Zertifikats-Nr.:	Anzahl der Seiten:	Gültig von:	Gültig bis:
S 814040	1	10.10.2014	09.10.2017

Geltungsbereich des Zertifikates:

Entwicklung, Herstellung und Vertrieb von Produkten und Systemen für Rauch- und Wärmeabzug, natürliche Gebäudelüftung, automatische Tür- und Toranlagen sowie damit verbundene Wartungs-, Dienst- und Serviceleistungen

Das Zertifikat umfasst ausschließlich das Qualitätsmanagementsystem in dem angegebenen Geltungsbereich. Die gegenwärtige Gültigkeit kann unter [www.vds.de](http://www.vds.de) verifiziert werden.

Das Zertifikat gibt keine Auskunft über die Zertifizierung von Qualitätsmanagementsystemen oder die VdS-Anerkennungen von Errichterfirmen, Wach- und Sicherheitsunternehmen, Produkten, Verfahren, o. ä. Hierfür sind gesonderte Nachweise erforderlich.

Das Zertifikat darf nur unverändert und mit sämtlichen Anlagen vervielfältigt werden. Während der Gültigkeit des Zertifikates muss das Qualitätsmanagementsystem der Organisation stets die Forderungen der Zertifizierungsgrundlagen erfüllen. Dies wird durch VdS Schadenverhütung regelmäßig begutachtet.

Jegliche Werbung mit dem Zertifikat muss den Inhalt korrekt wiedergeben und darf nicht auf wettbewerbsrechtswidrige Art und Weise erfolgen.

Zertifizierungsgrundlagen:

DIN EN ISO 9001  
 Qualitätsmanagementsysteme  
 Anforderungen  
 Ausgabe Dezember 2008  
 Qualitätsmanagementhandbuch des Zertifikatsinhabers

Köln, den 10.10.2014

Reinermann

Geschäftsführer

ppa. Urban

Leiter der Zertifizierungsstelle

VdS Schadenverhütung GmbH  
 Zertifizierungsstelle  
 Amsterdamer Str. 174  
 D-50735 Köln

Ein Unternehmen des Gesamtverbandes der Deutschen Versicherungswirtschaft e.V. (GDV)

Akkreditiert als  
 Zertifizierungsstelle für  
 Qualitätsmanagementsysteme von  
 der DAKS - Deutsche  
 Akkreditierungsstelle GmbH







**TRANSLATION OF THE ORIGINAL INSTRUCTIONS (GERMAN)**

Once the assembly and commissioning has been completed, the installer of a machine „power-operated window and door“ shall hand these instructions over to the end-user. The end-user shall store these instructions in a safe place for further reference and use, if required.

**Important note:**

We are aware of our responsibility, which is why we present life-supporting and value-preserving products with greatest possible conscientiousness. Although we make every effort to ensure that the data and information are as correct and up-to-date as possible, we still cannot guarantee that they are free from mistakes and errors.

All information and data contained in this document are subject to alterations without prior notice. Distribution and reproduction of this document as well as the use and disclosure of its content is not authorized unless expressly approved. Offenders will be held liable for the payment of damages. All rights reserved in the case of a patent award or utility model registration.

Basically the General Terms and Conditions of Aumüller Automatic GmbH apply to all offers, supplies and services.

The publication of these assembly and commissioning instructions supersedes all previous editions.

AUMÜLLER AUMATIC GMBH  
Gemeindewald 11  
86672 Thierhaupten

Tel. +49 8271 8185-0  
Fax +49 8271 8185-250  
info@aumueller-gmbh.de

[www.aumueller-gmbh.de](http://www.aumueller-gmbh.de)

9000019001\_V1.0\_KW16/16