

ROCK

INSTRUCTION MANUAL - TRANSLATION OF ORIGINAL INSTRUCTIONS

EN

LINEAR ROD ACTUATOR

Force 500 N – Strokes 100, 200 and 300 mm

Electrical supply: ■ 110-230V~ 50/60Hz, ■ 24V---

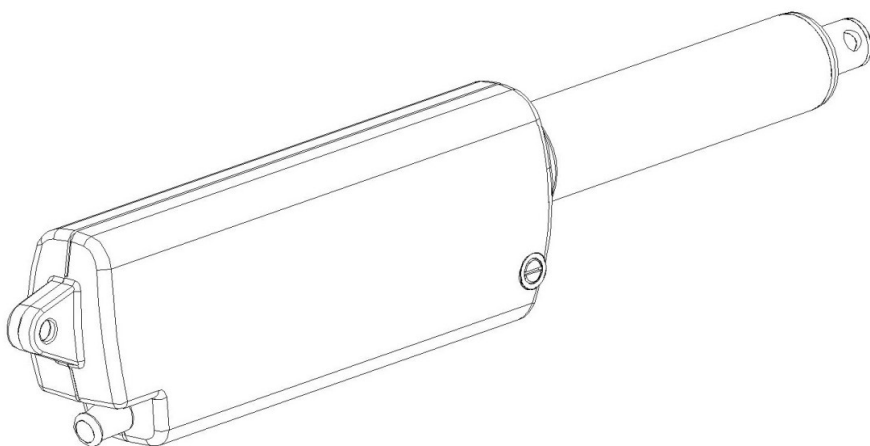

Nekos products have been manufactured in accordance with safety standards and conforms to the stipulations of current standards in force.

When correctly assembled, installed and used according to the present instructions, they will not generate any danger for persons, animals or items.

Symbols used in the manual



CAUTION

This indication highlights potential hazards for the safety and health of humans and animals.



INFORMATION

Information providing further suggestions.



WARNING

This indication highlights potential damage to property or to the product and its correct use.

CONTENTS

GENERAL INFORMATION	3
USER INSTRUCTIONS	3
INSTALLER INSTRUCTIONS	4
1. SECURITY RULES	4
2. FIELD OF APPLICATION	5
3. FORMULAS AND ADVICE FOR INSTALLATION.....	5
3.1. Calculation of opening / closure force	5
3.2. Maximum opening according to height of sash	5
4. TECHNICAL OPERATING INFORMATION.....	6
5. MANUFACTURE AND REGULATORY FRAMEWORK.....	6
6. ID PLATE AND MARKING DATA.....	7
7. TECHNICAL DATA	7
8. ELECTRICAL POWER SUPPLY	7
8.1. Choice of power cable diameter	8
9. RISK ANALYSIS	8
10. INSTALLATION INSTRUCTIONS.....	8
10.1. Preparing to mount the actuator.....	9
10.1.1. Preparation for mounting.....	9
10.2. Mounting the actuator.....	9
11. ELECTRICAL CONNECTION.....	10
11.1. Machine electrical connections	11
11.2. Connection with a K-LOCK electromechanical lock	11
12. PROGRAMMING THE ACTUATOR	12
13. CORRECT INSTALLATION CHECK	13
14. EMERGENCY MANOEUVRES AND MAINTENANCE	13
15. ENVIRONMENTAL PROTECTION.....	14
16. CERTIFICATE OF GUARANTEE	14
17. DECLARATION of INCORPORATION (for a partly completed machine) and EC.....	15

NEKOS S.r.l. - Via Capitoni, 7/5 - 36064 Colceresa (VI) – ITALY

☎ +39 0424 411011 – 📠 +39 0424 411013 - www.nekos.it - info@nekos.it

GENERAL INFORMATION

Before starting or using the actuator, read and understand all the parts of this instruction manual.

This manual is an integral part of the actuator and must be kept for future reference.

This documentation is intended for specialised companies and end users. All installation, maintenance and repair work should be carried out by suitably trained technical personnel.

After installation and testing, the technician must provide the user with these instructions and give a short demonstration of the use of the actuator.

USER INSTRUCTIONS



CAUTION: Carefully observe all the following installation instructions to ensure personal safety.

The device is **NOT** intended for use by persons (including children) with reduced physical, sensory or mental capabilities, or lacking experience and knowledge.

Do not allow children to play with the fixed controls and keep any remote-control units out of their reach.

Have installation checks performed periodically by qualified personnel from a service centre authorised by the manufacturer. Do not use if repair or adjustment is required.



CAUTION: if the power cable is damaged, it must be replaced by qualified personnel from a service centre authorised by the manufacturer.



CAUTION. Disconnect the power supply during cleaning or maintenance operations. Do not use solvents to wash the appliance;

In the event of a fault or malfunction, shut off the electrical supply at the main switch. All repairs and adjustments (e.g. stroke settings) must only be carried out by properly trained technical personnel with the professional and technical qualifications required under the current legislation in the country of installation.

Always request exclusive use of original spare parts. Failure to respect this condition could compromise safety and invalidate the benefits contained in the warranty for the appliance.

In the event of problems or queries, consult your trusted retailer or the manufacturer.

The A-weighted sound pressure level is less than 70dB(A).

Carefully preserve these instructions after installation.

INSTALLER INSTRUCTIONS

1. SECURITY RULES



CAREFULLY OBSERVE ALL THE FOLLOWING INSTALLATION INSTRUCTIONS TO ENSURE PERSONAL SAFETY. IMPROPER INSTALLATION CAN SERIOUSLY ENDANGER SAFETY.

The Nekos electrical actuators comply with the Machinery Directive (2006/42/EC), Standard IEC 60335-2-103 (Particular requirements for drives for gates, doors and windows) and other directives and regulations indicated in the attached Declarations of Incorporation and **CE** Conformity (at the end of the manual). According to the Machinery Directive, actuators are “partly completed machinery” intended for incorporation into doors and windows.

The manufacturer/supplier of the window is required, with exclusive responsibility, to ensure the compliance of the entire system with the applicable standards and to issue **CE** certification. We strongly discourage any use of the actuators other than that specified and therefore, in any case, the supplier of the complete system retains full liability.



MANDATORY RISK ANALYSIS AND PROTECTION MEASURES.

For systems installed at a height of less than 2.5 m above floor level or other levels accessible to users, the manufacturer/supplier of the window must conduct **risk analysis** regarding potential harm (violent blows, crushing, wounds) caused to people by normal use or possible malfunction or accidental breakage of the automated windows, and to implement suitable protective measures in view of these. Such measures include those recommended by the specified standard:

- controlling the actuators via a “deadman’s button” placed near the system and within the operator’s field of view, to ensure that people are out of the way during operation. The button must be placed at a height of 1,5 m and operated by key if accessible to the public; or
- use contact safety systems (also included in the devices) that ensure a maximum closing force of 400/150/25 N, measured in accordance with paragraph BB.20.107.2 of IEC 60335-2-103; or
- use of non-contact safety systems (lasers, light grids); or
- use of fixed safety barriers that prevent access to moving parts.

Automated windows are deemed adequately protected if they:

- are installed at a height of >2.5 m; or
- have a leading-edge opening of <200 mm and a closing speed of <15 mm/s; or
- are part of a smoke and heat evacuation system for emergency use only.

The device is not intended for use by persons (including children) with reduced physical, sensory or mental capabilities, or lacking experience and knowledge. Do not allow children to play with the fixed controls and keep any remote-control units out of their reach.

The actuator is destined exclusively for installation indoors. For any special application we recommend you consult the manufacturer beforehand.

Always request exclusive use of original spare parts. Failure to respect this condition could compromise safety and invalidate the benefits contained in the warranty for the appliance.

In the event of any problems or queries, consult your agent or contact the manufacturer directly.



2. FIELD OF APPLICATION

The ROCK actuator is intended for use in the ventilation and air conditioning of rooms through windows, sunsreen blades, louvre windows or jalousies. The movement is obtained with 110/230V~ or low-voltage (24V= SELV) electrical energy that powers a gear motor controlled by a functional electronic device. The Syncro³ technology patented by Nekos allows you to create synchronized systems of up to eight machines without any control unit.

3. FORMULAS AND ADVICE FOR INSTALLATION

3.1. Calculation of opening / closure force

Using the formulas on this page, approximate calculations can be made for the force required to open or close the window considering all the factors that determine the calculation.

The force required to move sunsreen blades, louvre windows or jalousies depends on the clutch system used on the fulcrums, the size of the blades and the wind pressure. Therefore, the calculation should be made by the system manufacturer, who knows their specification data.

Symbols used for the calculation

F (Kg) = Force for opening or closing

C (cm) = Opening stroke (actuator stroke)

P (Kg) = Weight of the window (mobile sash only)

H (cm) = Height of the mobile sash

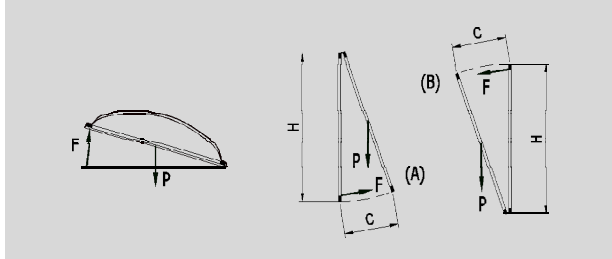

For horizontal light domes or skylights

$$F = 0,54 \times P$$

(Eventual weight of snow or wind on the cupola should be calculated separately.)

For vertical windows

◆ TOP HUNG WINDOWS, OUTWARD OPENING (A)

◆ BOTTOM HUNG WINDOWS (B)

$$F = 0,54 \times P \times C : H$$

(Eventual load of favourable or unfavourable wind on the sash should be calculated separately.)

3.2. Maximum opening according to height of sash

The choice of actuator stroke depends on the window height and its use with sunsreen blades or louvre windows. Check that the actuator does not touch the window profile during its stroke, that no obstacles impede opening and there is no forcing of the rod on the window frame.



WARNING. For safety, always check the application before fixing the actuator to the window. If difficulties arise, consult the manufacturer to check the application.

4. TECHNICAL OPERATING INFORMATION

ROCK is fitted with control electronics. It is equipped with a stiff rod that moves the levers of sunsreen blades or pushes the sash of a window or domed rooflight.

The stroke of the rod can be programmed along its entire stroke length by means of a magnetic switch (magnet-holder screw) (see section 12 - Programming the actuator).

The product is built in two versions, for a 110-230V~ 50/60Hz electrical supply or a 24V= low-voltage supply, with a maximum stroke of: 100 mm, 200 mm and 300 mm. It leaves the factory with the rod completely closed and can therefore also be installed without electricity, leaving the window closed after installation.

The return limit switch uses an electronic self-regulating process with power absorption and therefore there are no adjustments to be made.

The gear motor unit structure is made from high-strength composite material (Pa6 + 35%GF), with an IP66 protection rating, while the rod and reaction tube are made of anodised aluminium alloy. The steel brackets, treated against corrosion, are supplied with the actuator and are fixed to the frame or window with screws.

ROCK 24V combined with the **K-LOCK** product creates a burglar-proof window system and provides perfect window closure to ensure high thermal insulation values.

Window opening is easily programmed during installation by memorising the two stroke-end positions (OPEN and CLOSED). The actuator movement is equipped with a start and stop ramp to place less stress on the structural parts and extend their life, and it is also a safety device in accordance with standard EN 60335-2-103.

5. MANUFACTURE AND REGULATORY FRAMEWORK



INTENDED USE. The **ROCK** actuator is designed and built principally to open and close sunsreen blades, louvre windows and jalousies, as well as domed rooflights or industrial skylights; any other use is not recommended without prior approval from the manufacturer.

However, it should be noted that the installer of the entire system has sole responsibility for the application, as well as for failure to comply with the instructions given in this manual, as specified in the Machinery Directive.

The actuator is manufactured in accordance with the Directives and following Regulations listed in the attached Declaration of Incorporation and Conformity C€

Electrical connections must conform to regulations in force for the design and set up of electrical equipment.

The actuator is individually packaged in a cardboard box.

Each package contains:

- 1 Electric actuator complete with a 2 m power cable;
- Actuator attachment hardware comprising: 2 brackets for attaching the actuator and rod, 2 M6x30 bolts and 2 self-locking M6 nuts.
- Instruction manual.

6. ID PLATE AND MARKING DATA

The actuator have **CE** marking and comply with the Standards listed in the Declaration of Conformity. They also come with a Declaration of Incorporation, due to their classification by the Machinery Directive as “partly completed machines”. Both declarations are included in the final pages of this manual.

The plate data is displayed on an adhesive label placed on the outside of the casing, which must remain intact and visible. The main information it displays includes: manufacturer's address, product name - model number, technical characteristics, production date and serial number.

In the event of a complaint, please indicate the serial number (SN) displayed on the label.

An explanation of the symbols used on the label to abbreviate the technical characteristics is given in the table in the chapter on “*TECHNICAL DATA*”.

7. TECHNICAL DATA

ROCK Model	230 V	24 V
Force exerted by thrust and traction (F_N)	500 N	
Strokes (S_V)	100, 200, 300 mm	
Power supply voltage (U_N)	110-230V~ 50/60Hz	24 V _{SELV}
Rated absorbed current (I_N)	0,21 / 0,14 A	0,63 A
Power absorbed at nominal load (P_N)	17 W	15 W
Breaking current	0,80 A (a 24V)	
Electrical insulation	Class II	Class III
Average speed (<i>excluding starting and braking ramps</i>)	4 mm/s	
Stroke end position stop	Electronic with magnetic switch	
Ramp duration (<i>start and stop</i>)	1 s	
Service type (D_R)	2 cycles	5 cycles
Operating temperature	- 20 °C ↯ ↯ + 70 °C	
Electrical device protection rating	IP66	
Parallel power supply	YES	
Compatible with: K-LOCK and AUX accessory	NO	YES
Synchronisation (<i>Syncro³ patent</i>)	NO	YES (max 8)
Power cable length	2 m	
Noise level	55 dB-(A)	
Dimensions (<i>mm</i>)	72x34,5x344 / 444 / 594 mm	
Device weight	~ 0,890 Kg	~0,870 Kg

Any information reported in this table is not binding and may be susceptible to variations without notice.

8. ELECTRICAL POWER SUPPLY

ROCK actuator is powered with a voltage of:

- 110-230V~ 50/60Hz:
 - “SOLO” version - Three-wire power cable with **LIGHT BLUE**: neutral common; **BLACK**: open phase; **BROWN**: close phase

- 24V_{SELV} – Syncro³ Version - Three-wire power cable with **RED** connected to + (positive) CLOSE; **BLACK** connected to + (positive) OPEN; **GREEN** is the wire for the communication signal.

ROCK actuator in the 24V version can also be powered by a control unit with emergency batteries or a safety power supply of at least Class II, with an output voltage of 24V_{SELV} (min. 20,4V_{SELV}, max. 30V_{SELV}), sized according to the number of connected systems.

8.1. Choice of power cable diameter

The voltage drop caused by the flow of current in conductors is a critical aspect for the safety and proper functioning of the device. It is therefore important to correctly calculate the diameter of the conductors in relation to the length of the cables.

The following table shows the cable lengths for a gearmotor connected to a rated load.

CABLE DIAMETER	Actuator power supply		
	24V _{SELV}	110V~	230V~
0.50 mm ²	~20 m	~300 m	~1400 m
0.75 mm ²	~30 m	~450 m	~2100 m
1.00 mm ²	~40 m	~600 m	~2800 m
1.50 mm ²	~60 m	~900 m	~4000 m
2.50 mm ²	~100 m	~1500 m	~6800 m

9. RISK ANALYSIS

To estimate the risk potential of the motorised window and therefore implement the necessary protective measures, a risk assessment must already be conducted in the design stage. Risk analysis provides the information necessary for evaluating risk, in order to make decisions regarding the safety of the windows. Please refer to the Machinery Directive 2006/42/CE and the applicable parts of standards EN 13241-1, EN 12453 and EN 12445.

The machine as a whole may create crushing and shearing points on the sliding door/window and therefore a risk analysis must be made, in compliance with the guidelines of the sector associations and the Machinery Directive.

The risk analysis indicates making a prior analysis of where to position the actuator, the route of the power cables and the choice of where to fix the support brackets.



It should be noted that, according to the Machinery Directive, the manufacturer of the entire system has sole responsibility for the application and must also ensure perfect installation, in accordance with regulations.

10. INSTALLATION INSTRUCTIONS

These guidelines are intended for technical and specialised personnel; therefore, no comments are made on basic work and safety methods.

All preparation, installation and electrical connection operations must be carried out by a competent technician; this will ensure the optimal performance and proper functioning of the system.



If the system also includes an electromechanical lock, thought must be given at this stage to the installation of the lock and its electrical connection, which must be carried out together with that of the gearmotor.

First ensure that the following basic conditions are met:



Before installation, check that the moving parts of the door/window on which the product is to be installed are in perfect working condition, that they open and close properly and slide freely without any "stiff points";

The motor capacity must be sufficient for the required usage movements, without encountering obstacles of any kind; the limits indicated in the product technical data table (art. 7) may not be exceeded; otherwise eliminate any difficulties.



CAUTION Check that the electrical supply used corresponds to that specified on the "technical data" label on the device.

Check that the actuator has not been damaged during transportation, first visually and then by powering it in both directions.

10.1. Preparing to mount the actuator

In the case of doubts, uncertainty or different applications, consult the manufacturer.

For correct installation, carefully follow the instructions given below.

The following description is a recommendation by the manufacturer and describes the main installation steps, the sequence of which also depends on the type of use (windows, sunscreen blades, louvres or jalousies) and the structure.

10.1.1. Preparation for mounting

Before starting the assembly of the actuator, it is necessary to prepare following material for completion, equipment and tools:

- ◆ For fixing onto metal window frames: M5 threaded inserts (4 pieces), M5x12 flat headed metric screws (4 pieces).
- ◆ For fixing onto wooden window frames: self threading screws for wood Ø4.5 (4 pieces) of length appropriate to the type of window frame.
- ◆ For fixing onto PVC window frames: self threading screws for metal Ø4,8x16 (4 pieces) of length appropriate to the type of profile.
- ◆ Equipment and tools: measuring tape, pencil, drill/screwdriver, set of drill heads for metal, insert for screwing in, electricians pliers, screwdrivers.



WARNING The use self-tapping or self-drilling screws on aluminium windows is not recommended as these would tear the profile after a few manoeuvres; use metric screws with threaded inserts.

10.2. Mounting the actuator

Place the window or blade levers in the closed position. The actuator is supplied from the factory with the rod fully retracted (*closed position*). You can therefore evaluate and check whether the fixing points are correct and adequate for the movement to be performed.

Installation on windows:

- a) Having determined where to fix the actuator attachment bracket, position it on the frame or support, mark the two drilling points, drill with a bit of sufficient size and then fit the bracket.
- b) Provisionally mount the actuator on the bracket with the M6 bolt supplied, in order to have the exact measurement for positioning the second attachment bracket for the rod. Fit the rod attachment bracket with the other M6 bolt, place it on the window, mark the two drill points, drill with a bit of sufficient size and then also fit the rod bracket.

Installation on sunscreen blades, louvre windows or jalousies:

- c) Check that the actuator is in a fully closed position.
- d) Install the blade control lever attachment accessory and the actuator mounting bracket on the actuator with the M6 bolts supplied.

PLEASE NOTE *The accessory for sunscreen blades is not supplied and must be requested separately, unless the user has accessories of their own available.*
- e) Place the actuator support bracket on the window frame, mark the drill points, drill with a bit of sufficient size and fit the bracket.

At this point, you can power up the actuator in order to calibrate the stroke end positions and perform a complete opening/closing test.

When closure is completed, check that the limit switch has tripped in the desired position; *please note that the return limit switch uses an electronic self-regulating process with power absorption, therefore it is automatic and non-adjustable.*

Carry out the electrical connections following the instructions given in *section 11* below.



IMPORTANT Where one or more electric locks (K-LOCK) are included on the door/window, the electrical connections must be made at the same time; therefore, before connecting the cables, fit the lock following the instructions in the relevant manual.

11. ELECTRICAL CONNECTION



WARNING Electrically powered device

Danger of death from electric shock or fire. Disconnect the main switch before starting work to connect the device.

The machines are fitted with a 2-metre power cable manufactured in compliance with safety regulations and radio interference protection requirements, with PVC sheaths and conductors of 0,5 mm² in diameter. Any cable extensions must comply with the colours and specifications of the cable supplied with the machine.



EACH ACTUATOR MODEL HAS ITS OWN SPECIFIC CABLE, IN RELATION TO THE SUPPLY VOLTAGE. (see *section 8 – Electrical supply*).



Before making the electrical connection, check the following table to ensure that the power cable corresponds with the voltage data shown in the label on the actuator.

Supply voltage	Cable length	Number of wires	Power wires	Communication wires
110-230V~ 50/60Hz	2 m	3	LIGHT BLUE, BLACK BROWN	
24V --- Syncro ³	2 m	3	RED, BLACK	GREEN

11.1. Machine electrical connections



CAUTION Where several machines are connected in a Syncro³ system, always follow the correct electrical connections; incorrect connection can damage the machines and create a hazardous situation.



The electrical connection for communication and synchronisation (Green cable) must be made with a simple unipolar terminal of an appropriate size (the terminal is supplied).

A stable and safe connection, with a good electrical contact (copper to copper) is essential to prevent communication disturbances as the forward voltage is very low.

The communication wires can have a maximum length of 10 metres.

Wiring diagram 110/230V~

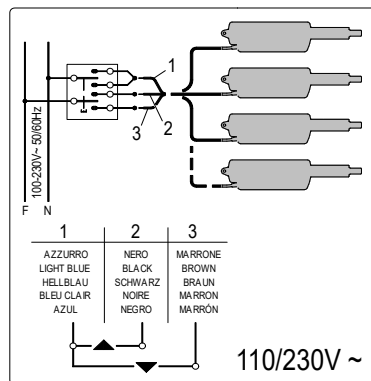

Wiring diagram 24V ---

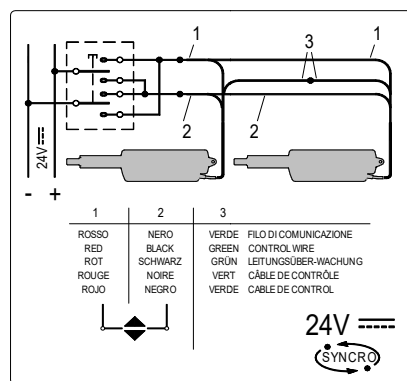

IMPORTANT FOR PRODUCT SAFETY: in motors with a 24V---, supply voltage, if the Green wire "3" is not used, it must be insulated.

11.2. Connection with a K-LOCK electromechanical lock

Wiring diagram 24V ---

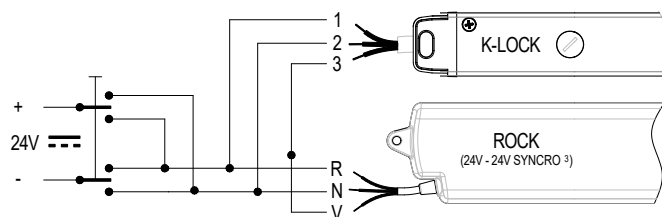

12. PROGRAMMING THE ACTUATOR



Before performing the stroke end-position setting procedure,

- make sure that the electrical power supplied to the actuator matches that indicated on the technical data label on the machine,
- check that the wires are correctly connected, in accordance with the wiring diagram in the previous chapter of this manual.

After testing, the actuator leaves the factory programmed to open to the maximum stroke available. To set the desired stroke, you will have to once more perform the opening stroke end-position setting procedure, as indicated below.



IMPORTANT Where two or more ROCK actuators are connected in a Syncro³ system, or with K-LOCK electromechanical locks, the recognition of the group is completely automatic and occurs in the first manoeuvre when programming the stroke end positions.

The closing stroke end position is automatic and cannot be programmed. The actuator stops due to the current absorption that occurs when the window or sunscreen blades close, that is, when the power absorbed exceeds a threshold pre-set by the manufacturer. The actuator considers any stroke end position within the last 1 cm valid.

After each closure or electronic protection intervention, the rod moves in the opposite direction by about 0,5-1,0 mm, to allow the right compression of the gaskets and/or relax the internal mechanical components of the actuator.

The RESET procedure must be carried out with the rod detached from the bracket. The stroke end-position setting or RESET procedures consist in the following steps, performed in sequence:

- Fully unscrew and remove the magnet-holder screw (indicated in the figure at the side) on the actuator.



NOTE: with several actuators in a Syncro³ system, there is NO need to remove the magnet-holder screw on the other machines as their recognition process is automatic;



- Supply power to move in either the opening or closing direction. With Syncro³ actuators, the rods move independently from each other.



CAUTION: if a K-LOCK is present (24V ROCK), you must wait around 4 seconds for it to switch to the OPEN position;

- The actuator moves automatically in the CLOSE direction up to the stroke end position and then (still automatically) in the OPEN direction, by about 3 cm.
- Disconnect the power to the machine.
- Refit the screw with the magnet and screw it into its housing;
- Connect the actuator rod to the bracket.
- The opening stroke can be customised as desired and must be determined at this stage. Command the actuator to OPEN to the desired distance (stroke customisation) or let it run to the stroke end position. **This outward distance will be memorised and used as the stroke end position in OPEN.** With Syncro³, the actuators move in synchronisation.
- Give a close command and check that the rod (or rods, with synchronised actuators) retracts to the stroke end position.

9. End of the procedure. In the event of errors in the previous steps, repeat the procedure

This procedure is carried out the first time the device performs a complete stroke and it is **stored as an operating parameter**.



IMPORTANT. If a K-Lock electromechanical lock is connected at a later moment, i.e. after acquisition of the stroke end positions, a new setting procedure or a new reset operation must be carried out.



CAUTION. In the event that, for whatever reason, the gearmotor has not closed the door/sash correctly, stopping before completing its stroke, the setting procedure or a reset operation must be repeated.

In the case of window sash automation, check, with the sash closed, that the gasket is properly compressed, otherwise there is no certainty that the window is fully closed and the lock properly engaged. Check also that the brackets are firmly attached to the frame and the screws properly tightened.

13. CORRECT INSTALLATION CHECK

After completing the installation, it is always necessary to check that the work has been done professionally, with no completion tasks left pending, and that the equipment is working properly. Therefore, ensure that:

- The window or sunscreen blades should close perfectly and there should be no hindrances due to inaccurate mounting positions.
- When the window is closed, the gaskets should be properly compressed, otherwise there is no certainty of a proper seal against atmospheric agents.
- The brackets should be firmly attached to the frame and the screws properly tightened.
- Where the K-LOCK electric lock is also installed, check that the lock is activated at the close stroke end position, with a closing time of around 4 seconds.
- Any casing covering the mechanisms is fitted so that it does not hinder the proper opening / closing operation of the door/sash.
- The power cables of the gearmotor and any locks are secured and protected in order to prevent dangling or interference with moving parts.

14. EMERGENCY MANOEUVRE AND MAINTENANCE

To open the window manually in the event of a power failure or fault in the mechanism, follow the procedure described below.

If an electromechanical lock K-LOCK is installed, to release it, see the indications given in the relevant instruction manual.

1. Remove the bolt securing the rod attachment bracket and remove the rod from its housing.
2. To facilitate the operation, move the window with small jolts in order to facilitate the extraction of the bolt from its housing.
3. Open the window or blades manually.
4. Once the emergency is resolved or the maintenance completed, carry out the operation in reverse.

CAUTION



To prevent damage to persons and property, observe the following:

- Before performing cleaning and maintenance operations, disconnect the actuator from the power outlet, without pulling on the power cord, to quickly disconnect the appliance.
- Disconnect the power supply to all terminals; remove the fuses if necessary.

15. ENVIRONMENTAL PROTECTION

All materials used in the manufacture of this appliance are recyclable.

We recommend that the device itself, and any accessories, packaging, etc. be sent to a centre for ecological recycling as established from laws in force on recycling. The device is mainly made from the following materials: aluminium, zinc, iron, plastic of various type, cuprum.

Dispose materials in conformity with local regulations about removal.

16. CERTIFICATE OF GUARANTEE

The manufacturer will guarantee good function of the appliance. The manufacturer shall undertake to replace defective parts due to poor quality materials or manufacturing defects in accordance with article 1490 of the Civil Code.

The guarantee covers products and individual parts for **2 years** from the date of purchase. The latter is valid as long as the purchaser possesses proof of purchase and completion of all agreed conditions of payment. Guarantee of good function of appliances agreed by the manufacturer implies that the latter undertakes to repair or replace free of charge and in the shortest period possible any parts that break while under warranty.

The purchaser is not entitled to any reimbursement for eventual direct or indirect damage or other expenses incurred. Attempt to repair by personnel unauthorised by the manufacture shall render the warranty null and invalid.

The warranty does not cover fragile parts or parts subject to natural wear and tear or corrosion, overload, however temporary etc. The manufacturer will accept no responsibility for eventual damage incurred by erroneous assembly, manoeuvre or insertion, excessive stress or inexperienced use.

Repairs performed under guarantee are always "*ex factory of the manufacturer*". Respective transport expenses (out/back) are the responsibility of the purchaser.

17. DICHIARAZIONE DI INCORPORAZIONE (PER UNA QUASI MACCHINA) e DICHIARAZIONE CE DI CONFORMITÀ / Declaration of incorporation (for a partly completed machine) and EC Declaration of Conformity.

Con la presente il / Hereby the

Costruttore: Manufacturer:	Nekos S.r.l. Via Capitoni 7/5- 36064 COLCERESA (Vicenza) - Italy Tel +39 0424 411011 – Email info@nekos.it
-------------------------------	--

dichiara sotto la propria responsabilità che i seguenti prodotti:
declare under its own responsibility that the following products:

Descrizione prodotto : Product Designation:	Attuatore elettrico a stelo Electric rod actuator
Modello: Type :	ROCK 230V ROCK 24V – ROCK 24V Syncro³

Anno di costruzione dal / Year of manufacturing from: **2020**

Soddisfano gli applicabili requisiti essenziali della Direttiva Macchine 2006/42/EC, Allegato I Fulfil the essential requirements of the Machinery Directive 2006/42/EC, Annex I, Art. 1.1.2, 1.1.3, 1.1.5, 1.2.1,1.2.3, 1.2.6; 1.3.2, 1.3.4, 1.3.9, 1.5.1, 1.5.2, 1.5.6, 1.5.7, 1.5.8, 1.5.9, 1.5.10, 1.5.11, 1.7.1, 1.7.1.1, 1.7.3, 1.7.4.2, 1.7.4.3 La documentazione tecnica pertinente è compilata secondo l' Allegato VII, sezione B The relevant technical documentation is compiled in accordance with Annex VII, Part B

La persona autorizzata a costituire la documentazione tecnica pertinente è:

The person authorised to compile the relevant technical documentation is:

Dr. ing. Matteo Stefani – Nekos S.r.l.

Su richiesta adeguatamente motivata delle autorità nazionali, la documentazione tecnica dei citati prodotti sarà resa disponibile, via e-mail, entro un tempo compatibile con la sua importanza.

In response to a reasoned request by the national authorities, we will provide, via e-mail, the relevant information on the product listed above within an adequate period proportional to its importance.

Inoltre i suddetti prodotti sono conformi alle disposizioni pertinenti delle seguenti Direttive:

Furthermore the products listed above complies with the provisions of followings Directives :

- **2014/30/EU Direttiva Compatibilità Elettromagnetica / ElectroMagnetic Compatibility Directive (EMCD)**
- **2014/35/EU Direttiva Bassa Tensione / Low Voltage Directive (LVD)**
- **2011/65/EU Direttiva sulla restrizione dell'uso di determinate sostanze pericolose nelle apparecchiature elettriche ed elettroniche (Direttiva RoHS) / Restriction of the use of certain hazardous substances Directive (RoHS Directive)**
- **2015/863/UE Direttiva Delegata recante modifica dell'allegato II della Direttiva 2011/65/UE del Parlamento Europeo e del Consiglio per quanto riguarda l'elenco delle sostanze con restrizioni d'uso / Delegated Directive amending Annex II of Directive 2011/65/EU of the European Parliament and of the Council regarding the list of substances with usage restrictions**

e delle seguenti norme armonizzate e/o specifiche tecniche:

and of the following harmonised standards and/or technical specifications:

EN 60335-2-103 ;	EN 61000-6-3:2007 + A1:2011;	EN 61000-6-2:2005 + AC:2005
EN 60335-1:2012 + EN 60335-1/A11:2014 ;	EN 50581:2012	

La messa in moto di una macchina completa che includa la quasi macchina sopra menzionata, da noi fornita, non è permessa finché non sia accertato che l'installazione sia stata fatta secondo le specifiche e le indicazioni di installazione contenute nel "Manuale d'istruzioni" fornito con la quasi-macchina e che sia stata espletata e documentata, in apposito protocollo, una procedura di accettazione da parte di un tecnico abilitato.

Commissioning of the complete machinery including the above mentioned drives delivered by us is not allowed until it is ascertained that the installation of the complete machinery was performed in accordance with the specifications and the operating and installation advice given in our Mounting Instructions, and that the acceptance procedure was duly carried out and documented in an acceptance protocol by a specialist.

Questa dichiarazione è fatta dal costruttore / This is declared by the manufacturer:

NEKOS SRL - Via Capitoni 7/5 - 36064 Colceresa (Vicenza) - Italy

Rappresentato da / Represented by :

Giuliano Galliazzo – Presidente A.D. / President CEO

Firma / Valid signature

Luogo e data / Place and date : Colceresa **20/06/2020**

	NEKOS S.r.l. - Via Capitoni, 7/5 36064 Colceresa (VI) – ITALY
	☎ +39 0424 411011 – 📠 +39 0424 411013 www.nekos.it info@nekos.it